

**CITY OF ROCHESTER HILLS
BROWNFIELD REDEVELOPMENT AUTHORITY**

BROWNFIELD PLAN

**ROCHESTER/AVALON RETAIL DEVELOPMENT
LOCATED AT 945 AND 975 SOUTH ROCHESTER ROAD
ROCHESTER HILLS, MICHIGAN**

July 6, 2021

Approved by RHBRA:
Approved by City Council:

DRAFT

Prepared on Behalf of:

Rochester Avon Partners, LLC
251 East Merrill Street
Birmingham, MI 48009
Contact Person: Doraid Markus
Telephone: (248) 892-2222

Prepared By:

PM Environmental, Inc.
4080 West Eleven Mile Road
Berkley, Michigan 48072
Contact Person: Ryan Higuchi
Telephone: (248) 414-1432



TABLE OF CONTENTS

PROJECT SUMMARY 1

I. INTRODUCTION AND PURPOSE 2

II. GENERAL PROVISIONS 2

A. Description of the Eligible Property (Section 13 (2)(h)) and Project.....2

B. Basis of Eligibility (Section 13 (2)(h) and Section 2(o)).....4

C. Summary of Eligible Activities and Description of Costs (Sec. 13 (2)(a-b)).....4

D. Estimate of Captured Taxable Value and Tax Increment Revenues (Sec. 13 (2)(c)).....6

E. Method of Brownfield Plan Financing and Description of Advances by the Municipality (Sec. 13 (2)(d))7

F. Maximum Amount of Note or Bonded Indebtedness (Sec. 13 (2)(e))7

G. Duration of Brownfield Plan (Sec. 13 (2)(f)).....7

H. Estimated Impact of Tax Increment Financing on Revenues of Taxing Jurisdictions (Sec. 13 (2)(g))7

I. Legal Description, Property Map, Statement of Qualifying Characteristics and Personal Property (Sec. 13 (2)(h))8

J. Displacement/Relocation of Individuals on Eligible Property (Sec. 13 (2)(i-l)).....9

K. Other Material that the Authority or Governing Body Considers Pertinent (Sec. 13 (2)(n)) ..9

APPENDICIES

- Appendix A Legal Description
- Appendix B Property Location Boundary
- Appendix C Preliminary Site Plans and Renderings
- Appendix D Documentation of Eligibility

TABLES

- Table 1: Estimated Costs of Eligible Activities
- Table 2: Tax Increment Revenue Capture Estimates
- Table 3: Tax Increment Reimbursement Estimates

PROJECT SUMMARY

Project Name:	Proposed Rochester/Avon Retail Development
Project Location:	The subject property is located at 945 and 975 South Rochester Road in Township three north (T3N), Range eleven east (R11E), Section 14, Rochester Hills, Oakland County Michigan 48307 (the "Property").
Type of Eligible Property:	The subject property is determined to be a "Property" under Part 213 of P.A. 451, as amended and the rules promulgated thereunder, and adjacent and contiguous as defined in Act 381.
Eligible Activities:	Pre-Approved Activities, Department Specific Activities, Asbestos Containing Materials (ACM) Abatement, Demolition, and Preparation of a Brownfield Plan.
Developer Reimbursable Costs:	\$508,553 (includes eligible activities and 15% contingency)
LBRF Capture	\$162,743
Years to Complete Reimbursement :	25 Years from start of capture
Estimated Capital Investment:	Approximately \$10,125,000 million (including Acquisition, Hard and Soft Costs)
Project Overview:	The proposed redevelopment will transform one of the City's busier intersections by demolishing an existing 1,407 square foot former gas station and a 5,409 commercial office building and redeveloping it into a modern, two-story, 26,575 square foot retail and office building. The first floor of the new building will support tenants that include retail, a drive thru restaurant, a credit union, and medical office space. The second floor will be used for office space. It is estimated that the project will create 100 construction jobs and 70 new permanent jobs in the first three years.

I. INTRODUCTION AND PURPOSE

In order to promote the revitalization of environmentally distressed, historic, functionally obsolete and blighted areas within the boundaries of Rochester Hills (“the City”), the City has established the Rochester Hills Brownfield Redevelopment Authority (RHBRA) the “Authority” pursuant to the Brownfield Redevelopment Financing Act, Michigan Public Act 381 of 1996, as amended (“Act 381”).

The purpose of this Brownfield Plan (the “Plan”) is to promote the redevelopment of and investment in the eligible “Brownfield” Property within the City and to facilitate financing of eligible activities at the Brownfield Property. Inclusion of Brownfield Property within any Plan in the City will facilitate financing of eligible activities at eligible properties and will provide tax incentives to eligible taxpayers willing to invest in revitalization of eligible sites, commonly referred to as “Brownfields.” By facilitating redevelopment of the Brownfield Property, this Plan is intended to promote economic growth for the benefit of the residents of the City and all taxing units located within and benefited by the Authority.

The identification or designation of a developer or proposed use for the Brownfield Property that is subject to this Plan shall not be integral to the effectiveness or validity of this Plan. This Plan is intended to apply to the eligible property identified in this Plan and, to identify and authorize the eligible activities to be reimbursed utilizing tax increment revenues. Any change in the proposed developer or proposed use of the eligible property shall not necessitate an amendment to this Plan, affect the application of this Plan to the eligible property, or impair the rights available to the Authority under this Plan.

This Plan is intended to be a living document, which may be modified or amended in accordance with and as necessary to achieve the purposes of Act 381. The applicable sections of Act 381 are noted throughout the Plan for reference purposes.

This Brownfield Plan contains information required by Section 13(2) of Act 381, as amended

II. GENERAL PROVISIONS

A. Description of the Eligible Property (Section 13 (2)(h)) and Project

The Eligible Property consists of three (3) legal parcels totaling approximately 2.199 acres with street addresses of 975 and 945 South Rochester Road, Rochester Hills, Oakland County, Michigan. The parcels and all tangible personal property located thereon will comprise the eligible property and is referred to herein as the “subject property.”

The subject property is located on the Rochester Road corridor, bounded by the commercial use to the north and east, Avon Road to the south, and South Rochester Road to the west. The subject property has been determined be a “Property”.

Property Address	Parcel ID	Approximate Acreage	Eligibility
975 S. Rochester Road	70-15-14-351-012	0.504 acres	Property
945 S. Rochester Road	70-15-14-351-011	0.505 acres	Adjacent and Contiguous
Unaddressed	70-15-14-351-068	1.190 acres	Adjacent and Contiguous

Rochester Avon Partners, LLC is the project developer (“Developer”). Rochester Avon Partners, LLC, is managed by Mr. Doriad Markus who has successfully completed numerous commercial retail developments in southeast Michigan. Some of these developments include the Holiday Inn Express in Birmingham that included the redevelopment of a 64-room hotel with several amenities, the Auburn Marketplace in Auburn Hills, a 12,000 square foot commercial retail development, and the Rochester Auburn commercial development in Rochester Hills, which included the development of over 32,000 square feet of commercial retail space over hour buildings. The success of these projects is reflective of Mr. Markus’ ability to attract both national and local tenants in the restaurant and hospitality industry.

The parcels are currently zoned B-1: Local Business District. The subject property is currently occupied by a 1,407 square foot vacant gas station building and a 5,409 square foot office building in an area characterized by commercial uses. Tenants of the office building will be leasing space in the new building. The zoning will remain unchanged as the current zoning permits the proposed future use.

Standard and historical sources document the parcel at 975 S. Rochester Road consisted of agricultural and vacant land from at least 1937 until between 1964 and 1967 when the current building was constructed in the northeastern portion. The building was utilized for gasoline service station operations from at least 1967 until 1999, when the building was renovated into the current convenience store and gasoline dispensing station. A canopy was constructed in the western portion in 1980, which was replaced with the current canopy in 1997. The subject property has operated as a gasoline dispensing station until 2020. The property is currently vacant.

The parcel at 945 S. Rochester Road was developed with agricultural fields from at least 1937 until between 1949 and 1957 when the current commercial building was constructed. Additions to the northern portion of the building were constructed in 1977. Occupants included a veterinarian hospital from at least 1957 until 1975 and various retail businesses and professional offices since the late 1970s. Occupants of the building prior to 1957 were unable to be identified. However, based upon the size and layout of the building during this time period, the building was likely utilized for similar veterinarian hospital operations prior to 1957. The property is currently occupied by three office tenants.

The unaddressed parcel, which is comprised of 1.19 acres and was previously part of a larger 2.33-acre parent parcel that is identified as 923 S. Rochester Road, was developed prior to 1940 with agricultural fields. A dwelling partially located on the subject property and north adjoining property was constructed in the northern portion between 1940 and 1949. Agricultural activities ceased and the former dwelling was renovated and expanded to the Avon Center Hospital in 1954, which extended onto the north adjoining property. Several additions were constructed to the hospital building and a garage structure was constructed in the northeastern portion of the subject property between 1957 and 1963. The former hospital was demolished between 1970 and 1971, and the current paved parking lot was completed. The former garage structure was demolished between 1980 and 1990, and the eastern and southeastern portions have remained vacant land since that time.

The subject property’s legal description is included in Appendix A. A parcel location map is included in Appendix B.

The proposed redevelopment includes demolition of the existing 1,407 square foot former gas station and 5,409 commercial office building to prepare the Property for a larger, two-story,

26,575 square foot commercial building. The project will feature retail, a restaurant, and office spaces on the ground level, with commercial office space on the second floor. Approximately 134 parking spaces will be created, as well as landscape and pathway improvements along the Rochester and Avon Roads that will improve the visual aesthetics of the intersection. The development will activate two currently vacant parcels and will maximize the use of the three parcels, which as a whole are currently underutilized.

Demolition activities are anticipated to begin in the fall of 2021. Construction will continue over a 12-month period. Rochester Avon Partners, LLC will invest an estimated \$10,125,000 in the development and create approximately 100 construction jobs and 70 permanent Full Time Equivalent (FTE) jobs in the first three years.

Preliminary site plans and renderings are included in Appendix C.

B. Basis of Eligibility (Section 13 (2)(h) and Section 2(o))

The Property is considered “Eligible Property” as defined by Act 381, Section 2 because the parcel located at 975 S. Rochester Road, which is a part of the subject property, has been determined to be a “Property” under Part 213 of P.A. 451, as amended and the rules promulgated thereunder. The unaddressed parcel (PID 70-15-14-351-068) and the parcel located at 945 S. Rochester Road are eligible parcels that are adjacent or contiguous and are estimated to increase the captured taxable value of the project.

Contaminant concentrations of volatile organic compounds (VOCs) that include benzene, toluene, ethylbenzene, xylenes, 1,2,4-trimethylbenzene, naphthalene, and 2-methylnaphthalene were identified in the soil and groundwater at the subject property above Part 213 Residential and Nonresidential criteria for Drinking Water Protection (DWP)/Drinking Water (DW) and Groundwater Surface Water Interface Protection (GSIP)/Groundwater Surface Water Interface (GSI) Risk Based Screening Levels (RBSLs). Based on these analytical results and the closed Leaking Underground Storage Tank (LUST) status, the subject property is classified as a “Property” in accordance with Part 213 of P.A. 451 of 1994, as amended and the results promulgated thereunder.

Additional documentation and description of the property’s “Property” status is provided in Appendix D.

C. Summary of Eligible Activities and Description of Costs (Sec. 13 (2)(a-b))

Tax Increment Financing revenues will be used to reimburse the costs of “Eligible Activities” (as defined by Section 2 of Act 381) as permitted under the Brownfield Redevelopment Financing Act that include: Pre-Approved Activities, Department Specific Activities, Demolition, Asbestos Activities and preparation and implementation of a Brownfield Plan and Act 381 Work Plan. A complete itemization of these activities and associated expenses is included in Table 1.

The following eligible activities and budgeted costs are intended as part of the development of the property and are to be financed solely by the developer. All activities are intended to be “Eligible Activities” under the Brownfield Redevelopment Financing Act. The Authority is not responsible for any cost of eligible activities and will incur no debt.

1. Pre-Approved Activities include a Phase I and II Environmental Site Assessment (ESA), baseline environmental assessment (BEA), and Hazardous Materials Survey required as

**Brownfield Plan for the Proposed Rochester/Avon Retail Development
Located at 945 and 975 South Rochester Road, Rochester Hills, Michigan
PM Project No. 01-11390-0-0003; July 6, 2021**

part of the pre-purchase due diligence conducted on the property at a total cost of \$15,325.

2. Department Specific Activities include Due Care Activities to facilitate redevelopment.

The developer is pursuing the Michigan Underground Storage Tank Authority (MUSTA) to address contamination on the property related to a confirmed release (REL-0223-19). MUSTA eligible costs are anticipated to include the removal and disposal of contaminated soil and groundwater above Part 213 Non-Residential Risk-Based Screening Level (RBSL) criteria, and the backfilling of the site. It is currently estimated that up to 1,500 tons of contaminated soil will be excavated and backfilled under MUSTA, however this volume may increase pending additional sampling, field conditions and approval from MUSTA. The costs covered by MUSTA will not be covered nor requested under the Brownfield Plan.

However, residual contamination is anticipated to remain in both soil and groundwater and additional Due Care Activities beyond the excavation funded by MUSTA will be required. These activities include the design and installation of a vapor barrier system; chemical-resistant gasketing for utilities; utility corridor migration barriers; underground storage tank (UST) removal; contaminated soil transport and disposal related to utility trenching, building footings etc., contaminated groundwater treatment and disposal, and oversight/sampling/reporting by an environmental professional at a total estimated cost of \$275,850.

Proper transport and disposal of contaminated soils remaining following MUSTA funded activities related to Due Care to facilitate development of the subject property are based on the following soil volume estimates, which are limited to the contaminated areas of the subject property:

Utility Trenching						
	Linear Feet	Estimate Pipe Diameter (")	Estimated Trench Depth (FT)	Estimated Trench Volume (CF) (Per linear foot, at 1:1 setback)	Estimated Trenching Volume for Disposal (CY)	Estimated Trenching Soil Weight for Disposal (TN)
Storm Sewer	200	18	5	20	148	244
TOTAL					148	244
Building Perimeter Footings						
Linear Feet	Estimated Trench Depth (FT)	Estimated Footing Width (")	Estimated Trench Volume (CF) (Per linear foot, at 1:1 setback)	Estimated Trenching Volume for Disposal (CY)	Estimated Trenching Soil Weight for Disposal (TN)	
100	4	24"	37.5	139	229	
TOTAL					139	229
Building Pad Cut (estimate assumes 12" cut)						
	Estimated Pad Area (SF)	Estimated Volume (CY)	Estimated Pad Cut Soil Weight for Disposal (TN) - Csoil Only			
Building	550	20	34			
TOTAL		20	34			

**Brownfield Plan for the Proposed Rochester/Avon Retail Development
Located at 945 and 975 South Rochester Road, Rochester Hills, Michigan
PM Project No. 01-11390-0-0003; July 6, 2021**

Non-Building Pavement			
	Estimated Pavement Area (SF)	Estimated Volume (CY)	Estimated Pavement Cut Soil Weight for Disposal (TN)
Non-Building Pavement – (contaminated areas only)	12,000	369	609
TOTAL		369	609

3. Demolition Activities includes building demolition and the removal of parking lots at an estimated cost of \$120,000.
4. Asbestos Activities includes asbestos containing materials (ACM) abatement, oversight, air monitoring and associated reporting at an estimated cost of \$20,000.
5. Preparation and implementation of the Brownfield Plan and associated activities (e.g. meetings with BRA, review by City Attorney etc.) at a cost of approximately \$15,000.
6. A 15% contingency of \$59,378 is established to address unanticipated environmental and/or other conditions that may be discovered through the implementation of site activities. This excludes the cost of Pre-Approved Activities and preparation of the Brownfield Plan.

All activities are intended to be “Eligible Activities” under the Brownfield Redevelopment Financing Act. The total estimated cost of Eligible Activities subject to reimbursement from tax increment revenues is \$446,175 with a potential \$62,378 contingency, resulting in a total cost of \$508,553, the total cost for reimbursement to the applicant is a not-to-exceed amount of \$508,553 (including contingency), unless the Plan is amended and approved by the BRA and City Council.

D. Estimate of Captured Taxable Value and Tax Increment Revenues (Sec. 13 (2)(c))

Incremental taxes on real property included in the redevelopment project will be captured under this Plan to reimburse eligible activity expenses. The base taxable value of the subject property shall be determined by the use of the 2021 tax year tax values, which is \$617,020. Tax increment revenue capture will begin when tax increment is generated by redevelopment of the subject property, which is expected to begin in 2023 or when full redevelopment is completed whichever occurs first. The estimated post development taxable value of the completed development is \$1,728,400 and is based on an average between a cost approach of 35% of the hard cost investment and a comparable approach of similar properties within the City. Following completion of the project, the actual taxable value will be determined via the property assessment process by the City of Rochester Hills. An annual increase in taxable value of 1% has been used for calculation of future tax increments in this Plan. Tables 2 details the estimate of captured tax increment revenues for each year of the Plan from the eligible property.

The RHBRA has established a Local Brownfield Revolving Fund (LBRF). Per the RHBRA policy, capture for the LBRF is included in this plan for five (5) years following developer reimbursement, as well as an annual 3% capture of the total local increment revenue, currently estimated at \$162,743. The funds deposited into the LBRF as part of this Plan will be used in accordance with the requirements of Act 381, as amended.

Prior to reimbursement of tax increment revenue to the Developer, payment of Brownfield Redevelopment Authority Administrative fees, and the 3% capture for the Local Brownfield

Revolving Fund (LBRF) will occur first. Additional LBRF capture will occur at the end of the Plan for five (5) years as shown in Table 2.

E. Method of Brownfield Plan Financing and Description of Advances by the Municipality (Sec. 13 (2)(d))

Eligible activities will be financed by Rochester Avon Partners, LLC. The Developer will be reimbursed for eligible costs as described in Section C and outlined in Table 1. Costs for Eligible Activities funded by Rochester Avon Partners, LLC will be repaid under the Michigan Brownfield Redevelopment Financing Program (Michigan Public Act 381, as amended) with incremental taxes generated by future development of the property. The estimated amount of tax increment revenue capture that will be used to reimburse the Developer, the Brownfield Redevelopment Authority Administration Fees, and LBRF is \$706,627.

No advances will be made by the RHBRA for this project. All reimbursements authorized under this Plan shall be governed by the Reimbursement Agreement.

F. Maximum Amount of Note or Bonded Indebtedness (Sec. 13 (2)(e))

No note or bonded indebtedness will be incurred by any local unit of government for this project.

G. Duration of Brownfield Plan (Sec. 13 (2)(f))

In no event shall the duration of the Plan, exceed 35 years following the date of the resolution approving the Plan, nor shall the duration of the tax capture exceed the lesser of the period authorized under subsection (4) and (5) of Section 13 of Act 381 or 30 years. The Property will become part of this Plan on the date this Plan is approved by the City of Rochester Hills City Council.

H. Estimated Impact of Tax Increment Financing on Revenues of Taxing Jurisdictions (Sec. 13 (2)(g))

Taxes will continue to be generated to taxing jurisdictions on local captured millages at the base taxable value of \$617,020 throughout the duration of this Plan totaling approximately \$326,447 or \$13,058 annually.

School millages; including the State Education Tax and the Rochester School Operating Millage, are not captured under this plan and will have an immediate increase in tax revenue following redevelopment of approximately \$801,361 throughout the duration of this Plan.

Non-capturable millages; including debt millages, the zoo authority and art institute, will have an immediate increase in tax revenue following redevelopment of approximately \$132,565 throughout the duration of this Plan.

A summary of the impact to taxing jurisdictions for the life of the Plan is summarized below, the amount captured is the sum of developer eligible activity and interest reimbursement, administrative fees and the state brownfield revolving fund.

**Brownfield Plan for the Proposed Rochester/Avon Retail Development
Located at 945 and 975 South Rochester Road, Rochester Hills, Michigan
PM Project No. 01-11390-0-0003; July 6, 2021**

Millage	Rate	Developer Reimbursement	Admin Fee	LBRF Capture	Taxes Preserved for Taxing Units
State Education	6.0000	\$0	\$0	\$0	\$292,893
School Operating	18.0000	\$0	\$0	\$0	\$878,680
Subtotal	24.0000	\$0	\$0	\$0	\$1,171,573
County Operating	4.0200	\$96,603	\$6,711	\$30,914	\$62,011
School Sinking	1.4874	\$35,743	\$2,483	\$11,438	\$22,944
Oak Int SD-Alloc	0.1918	\$4,609	\$320	\$1,475	\$2,959
Oak Int SD-Vtd.	3.0362	\$72,961	\$5,069	\$23,349	\$46,835
Oak Comm College	1.5184	\$36,488	\$2,535	\$11,677	\$23,422
Oakland County Parks	0.3500	\$8,411	\$584	\$2,692	\$5,399
Huron Clinton Parks	0.2104	\$5,056	\$351	\$1,618	\$3,246
General Fund	2.6909	\$64,664	\$4,492	\$20,693	\$41,508
Local Street	1.0868	\$26,116	\$1,814	\$8,358	\$16,764
Fire Fund	2.7000	\$64,882	\$4,508	\$20,763	\$41,649
Special Police I	1.1552	\$27,760	\$1,929	\$8,884	\$17,820
Special Police II	1.1891	\$28,575	\$1,985	\$9,144	\$18,342
Pathway	0.1773	\$4,261	\$296	\$1,363	\$2,735
RARA Operating	0.1861	\$4,472	\$311	\$1,431	\$2,871
OPC Operating	0.3200	\$7,690	\$534	\$2,461	\$4,936
OPC Transportation	0.0954	\$2,293	\$159	\$734	\$1,472
Library Operating	0.7478	\$17,970	\$1,248	\$5,751	\$11,535
Subtotal	21.1628	\$508,553	\$35,331	\$162,743	\$326,447
Total Capturable Millages	21.1628	\$508,553	\$35,331	\$162,743	\$326,447
Non-Capturable Millages by Brownfield TIF					
Rochester Sch. Debt	3.4800	\$0	\$0	\$0	\$169,878
Zoo Authority	0.0965	\$0	\$0	\$0	\$4,711
Art Institute	0.1913				\$9,338
Chapter 20 Drain Debt	0.0364	\$0	\$0	\$0	\$1,777
OPC Building Debt	0.1660	\$0	\$0	\$0	\$8,103
Total Non-Capturable Millages	3.9702	\$0	\$0	\$0	\$193,807

See Table 2 for a complete breakdown of estimated available tax increment revenue and Table 3 for the estimated annual reimbursement.

I. Legal Description, Property Map, Statement of Qualifying Characteristics and Personal Property (Sec. 13 (2)(h))

The legal description of the Property included in this Plan is attached in Appendix A.

Property location maps are included in Appendix B.

Documentation of characteristics that qualify the property as eligible property is provided in Appendix D.

Personal property may be included as part of the eligible property to the extent that it is taxable personal property.

J. Displacement/Relocation of Individuals on Eligible Property (Sec. 13 (2)(i-l))

No displacement of residents or families is expected as part of this project.

K. Other Material that the Authority or Governing Body Considers Pertinent (Sec. 13 (2)(n))

The Brownfield Redevelopment Authority and the City Council as the Governing Body, in accordance with the Act, may amend this Plan in order to fund additional eligible activities associated with the Project described herein.

DRAFT

Attachment A

DRAFT



Legal Descriptions

975 South Rochester Road, Rochester Hills, Oakland County, Michigan:

Parcel: 70-15-14-351-012

T3N, R11E, SEC 14 PART OF SW 1/4 BEG AT PT DIST S 89-51-30 E 33 FT & N 60 FT FROM SW SEC COR, TH N 135 FT, TH E 162.50 FT, TH S 135 FT, TH W 162.50 FT TO BEG 0.51 AB203A

945 South Rochester Road, Rochester Hills, Oakland County, Michigan:

Parcel: 70-15-14-351-011

T3N, R11E, SEC 14 PART OF SW 1/4 BEG AT PT DIST S 89-51-30 E 33 FT & N 195 FT FROM SW 1/4 COR, TH N 135 FT, TH E 162.50 FT, TH S 135 FT, TH W 162.50 FT TO BEG 0.50 AB203B

Unaddressed Parcel, Rochester Hills, Oakland County, Michigan:

Parcel: 70-15-14-351-068

T3N, R11E, SEC 14 PART OF SW 1/4 BEG AT PT DIST S 89-51-30 E 195.50 FT & N 60 FT FROM SW SEC COR, TH N 270 FT, TH S 89-51-30 E 58 FT, TH S 24.30 FT, TH S 89-51-30 E 85 FT, TH N 24.30 FT, TH S 89-51-30 E 57 FT, TH S 270 FT, TH N 89-51-30 W 200 FT TO BEG 1.19 A 11-12-20 FR 062

DRAFT

Attachment B

DRAFT



Map



- 2 Foot Contours
- 5 Foot Contours
- FEMA Base Flood Elevations
- FEMA Cross Sections
- 100 yr - FEMA Floodplain
- 100 yr (detailed) - FEMA Floodplain
- 500 yr - FEMA Floodplain
- FLOODWAY - FEMA Floodplain

Disclaimer: The information provided herewith has been compiled from recorded deeds, plats, tax maps, surveys and other public records. It is not a legally recorded map or survey and is not intended to be used as one. Users should consult the information sources mentioned above when questions arise. FEMA Floodplain data may not always be present on the map.

OAKLAND COUNTY MICHIGAN
 Economic Development & Community Affairs
L. Brooks Patterson
 Oakland County Executive

Date Created: 8/14/2019
NORTH
 1 inch = 200 feet

W 1/4 CORNER SECTION 14
T.03N., R.11E
CITY OF ROCHESTER HILLS
OAKLAND COUNTY, MI
REMON IN MON BOX

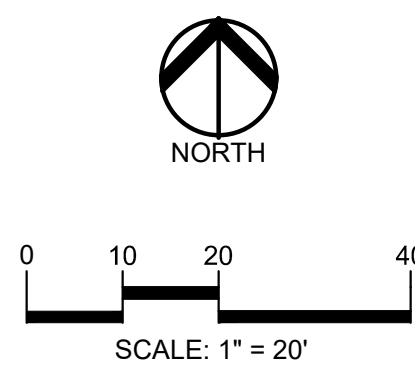
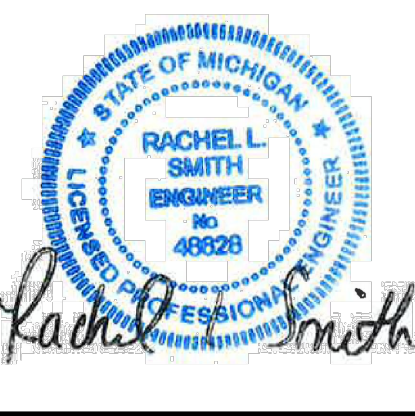

CAUTION!
THE LOCATION AND ELEVATIONS OF EXISTING UNDERGROUND UTILITIES AS SHOWN ON THIS DRAWING ARE ONLY APPROXIMATE. NO GUARANTEE IS EITHER EXPRESSED OR IMPLIED AS TO THE COMPLETENESS OR ACCURACY THEREOF. THE CONTRACTOR SHALL BE EXCLUSIVELY RESPONSIBLE FOR DETERMINING THE EXACT UTILITY LOCATIONS AND ELEVATIONS PRIOR TO THE START OF CONSTRUCTION.

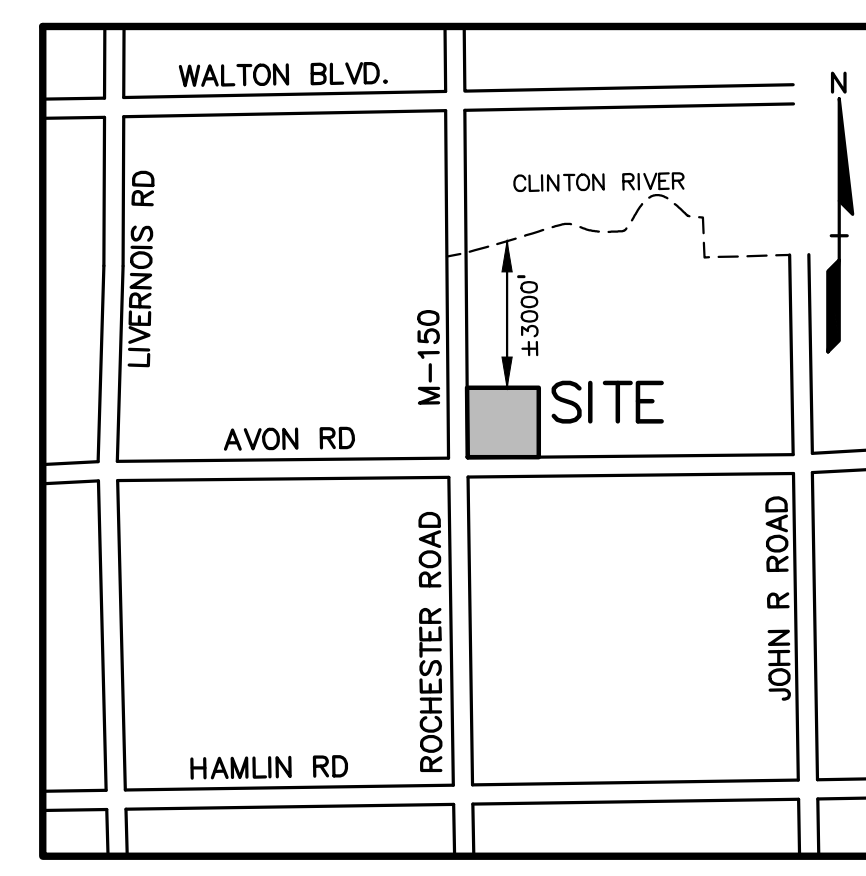

LEGEND

● IRON FOUND	● BRASS PLUG SET	● SEC. CORNER FOUND
⊗ IRON SET	⊗ MONUMENT SET	○ RECORDED
⊗ NAIL FOUND	⊗ MONUMENT SET	M MEASURED
⊗ NAIL & CAP SET		C CALCULATED

EXISTING

- OH-ELEC-W-O ELEC. PHONE OR CABLE TV OH LINE, POLE & GUY WIRE
- UG-CATV ELEC. UNDERGROUND CABLE TV, CATV PEDESTAL
- UG-UG-FIBER TELEPHONE U.G. CABLE FIBER/STAIR & MANHOLE
- UG-ELEC-ELEC. ELECTRIC U.G. CABLE, MANHOLE, METER & HANDHOLE
- UG-GAS GAS MAIN, VALVE & GAS LINE MARKER
- WATERMAN. HYD. WATER MAIN, VALVE, TAPPING SLEEVE & VALVE
- SANITARY SEWER, CLEANOUT & MANHOLE
- STORM SEWER, CLEANOUT & MANHOLE
- SQ. ROUND & RECT. CATCH BASIN, YARD DRAIN
- WATER VALVE, BACKFLOW PREVENTER, VALVE BOX, SERVICE SHUTOFF
- WALKBOX, TRANSFORMER, REGULATOR, CONTROL VALVE
- UNDERTIED STRUCTURE
- SPOT ELEVATION
- CONTOUR LINE
- FENCE
- GUARD RAIL
- STREET LIGHT
- SKIN
- CONC. CONCRETE
- ASPH. ASPHALT

REFERENCE DRAWINGS

- WATER MAIN CITY OF ROCHESTER HILLS GIS MAP
- SANITARY SEWER CITY OF ROCHESTER HILLS GIS MAP
- STORM SEWER CITY OF ROCHESTER HILLS GIS MAP
- ELECTRIC NOT RECEIVED
- PHONE NOT RECEIVED
- GAS CONSUMERS ENERGY MAP# 03-61-14-3, DATED 01/10/19
- NO FACILITIES IN THE AREA
- PETROLEUM CITY CONSUMERS ENERGY MAP# RECEIVED 02/19/19
- FLOOD PLAN FIRM MAP 26125C0392F, DATED 08/29/06, ZONE "X"
- MDOT ROAD PLANS, VARIOUS PROJECTS
- BOUNDARY/TOPOGRAPHIC SURVEY, COMERICA BANK, #F 0448, DATED 12/21/20
- OTHER PARTIAL GRADING/UTILITY PLAN, COMERICA BANK, UNDATED

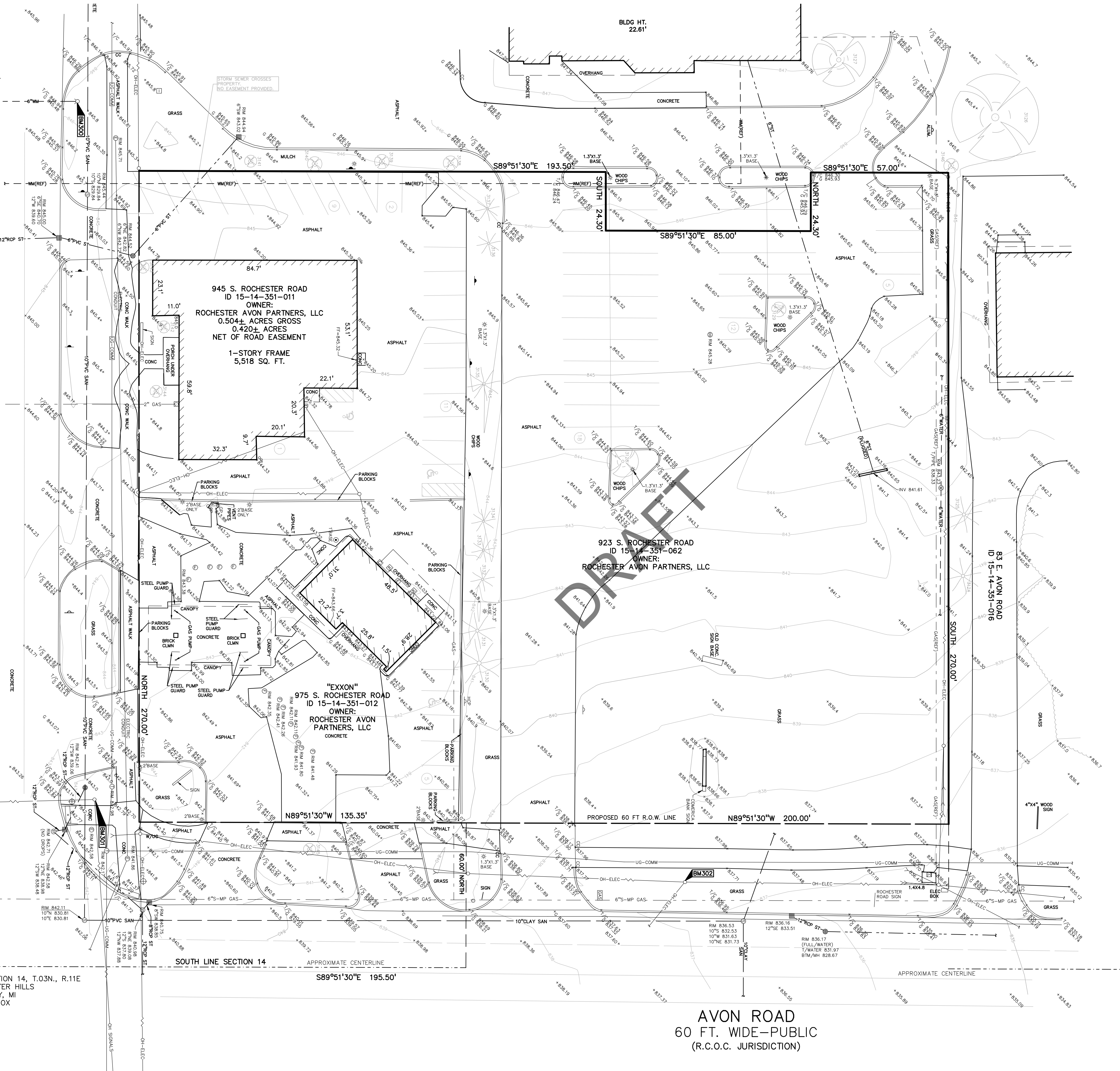

BENCHMARKS
(GPS DERIVED - NAVD88)

BM #300
CUT "X" ON NORTHEAST BOLT HYDRANT EAST SIDE ROCHESTER ROAD, ±350' NORTH OF AVON ROAD.
ELEV. - 846.92'

BM #301
CUT "X" ON SOUTHWEST BOLT OF STEEL STRAIN POLE AT NORTHEAST CORNER OF AVON AND ROCHESTER ROAD.
ELEV. - 844.05'

BM #302
SET BENCHMARK IN NORTH FACE OF UTILITY POLE NORTH SIDE OF AVON ROAD, ±300' EAST OF ROCHESTER ROAD.
ELEV. - 838.42'

EXISTING SOIL INFORMATION:

PER THE WEB SOIL SURVEY OF OAKLAND COUNTY, AS PUBLISHED BY THE USDA-NRCS, VERSION 19, DATED JUNE 1, 2020, THIS SITE CONSISTS OF SOILS OF THE FOLLOWING TYPE:

59 - URBAN LAND

LEGAL DESCRIPTION
COMBINED PROPERTY

LAND IN A PART OF SOUTHWEST 1/4 SECTION 14, TOWN 3 NORTH, RANGE 11 EAST, CITY OF ROCHESTER HILLS, OAKLAND COUNTY, MICHIGAN, DESCRIBED AS FOLLOWS:

COMMENCING AT THE SOUTHWEST SECTION CORNER OF SAID SECTION 14, THENCE SOUTH 89 DEGREES 51 MINUTES 30 SECONDS EAST 195.50 FEET ALONG THE SOUTH LINE OF SECTION 14; THENCE NORTH 60.00 FEET TO THE NORTH LINE OF AVON ROAD (120 FEET WIDE) AND THE POINT OF BEGINNING; THENCE ALONG SAID NORTH LINE NORTH 89 DEGREES 51 MINUTES 30 SECONDS WEST 135.35 FEET TO THE EAST LINE OF S. ROCHESTER ROAD (WIDTH VARIES); THENCE ALONG SAID EAST LINE NORTH 27.00 FEET; THENCE SOUTH 89 DEGREES 51 MINUTES 30 SECONDS EAST 193.50 FEET; THENCE SOUTH 24.30 FEET; THENCE SOUTH 89 DEGREES 51 MINUTES 30 SECONDS EAST 85.00 FEET; THENCE NORTH 24.30 FEET; THENCE S89°51'30"E 57.00 FEET; THENCE SOUTH 270.00 FEET TO THE NORTH LINE OF SAID AVON ROAD; THENCE ALONG SAID NORTH LINE NORTH 89 DEGREES 51 MINUTES 30 SECONDS WEST 200.00 FEET TO THE POINT OF BEGINNING, CONTAINING ±2.03 ACRES

ORIGINAL ISSUE DATE: MAY 10, 2021

DRAWING TITLE
TOPOGRAPHIC SURVEY

PEA JOB NO. 2019-007

P.M.	RLS
DN.	PB
DES.	PB

DRAWING NUMBER:
C-1.0

FLOODPLAIN:
BY GRAPHIC PLOTTING, THE SUBJECT PARCEL IS IN "AREAS DETERMINED TO BE OUTSIDE OF THE 0.2% ANNUAL CHANCE FLOODPLAIN" (ZONE X) PER FEMA FLOOD INSURANCE RATE MAP PANEL NUMBER 26125C0392F, EFFECTIVE DATE SEPTEMBER 29, 2006

CLIENT
ROCHESTER AVON PARTNERS, LLC
251 EAST MERRILL STREET, SUITE #205
BIRMINGHAM, MICHIGAN, 48009

PROJECT TITLE
RETAIL REDEVELOPMENT
N.E.C. ROCHESTER ROAD AND AVON ROAD
CITY OF ROCHESTER HILLS, OAKLAND COUNTY, MI

REVISIONS

NO.	DATE	DESCRIPTION

PEA JOB NO. 2019-007

P.M.	RLS
DN.	PB
DES.	PB

DRAWING NUMBER:
C-1.0

ROCHESTER ROAD
120 FT. WIDE-PUBLIC
(MDOT JURISDICTION)

SW CORNER SECTION 14, T.03N., R.11E
CITY OF ROCHESTER HILLS
OAKLAND COUNTY, MI
REMON IN MON BOX

AVON ROAD
60 FT. WIDE-PUBLIC
(R.C.O.C. JURISDICTION)

Attachment C

DRAFT



W 1/4 CORNER SECTION 14
T.03N., R.11E
CITY OF ROCHESTER HILLS
OAKLAND COUNTY, MI
REMON IN MON BOX

RAMP LANDINGS TO BE
CONCRETE WITH DETECTABLE
WARNING AND ARE TO BE
INSTALLED AT MAX. SLOPE OF 2%

8' WIDE ASPHALT PATH, TYP.
REFER TO DETAILS ON C-9.1

HEAVY DUTY ASPHALT
PAVEMENT, TYP. REFER TO
DETAIL ON SHEET C-9.1

STANDARD DUTY ASPHALT
PAVEMENT, TYP. REFER TO
DETAIL ON SHEET C-9.1

SEGMENTAL BLOCK RETAINING
WALL ALONG PROPERTY LINE.
HEIGHT VARIES (0"-12")

AMENITY AREA (SHADED)
PATH, BENCHES, BIKE RACKS,
ETC. AREA = 1,795 SQ.FT.
REFER TO LANDSCAPE PLANS
FOR ADDITIONAL DETAILS

1.5' VEHICLE OVERHANG, TYP.

18"x6" CONCRETE CURB
AND GUTTER, TYP. REFER
TO DETAIL ON SHEET C-9.1

CONCRETE CURB
SPILLWAY, REFER TO
DETAIL ON SHEET C-9.1

PARKING SPACES FOR
COMERICA BANK

STANDARD DUTY ASPHALT
PAVEMENT, TYP. REFER TO
DETAIL ON SHEET C-9.1

DETAIL M GUTTER PAN, TYP.
REFER TO M.D.O.T. DETAIL R-29
ON CONSTRUCTION PLANS

30" WIDE F-5 CURB AND GUTTER.
REFER TO M.D.O.T. DETAIL R-30
ON CONSTRUCTION PLANS

RIGHT-IN, LEFT-IN AND RIGHT-OUT
DRIVE APPROACH. REFER TO
M.D.O.T. DETAIL GEO-680

NOTE:
ALL WORK WITHIN THE ROCHESTER
ROAD (M-150) RIGHT-OF-WAY IS
UNDER THE JURISDICTION OF THE
MICHIGAN DEPT. OF TRANSPORTATION
AND REQUIRES A PERMIT.

ALL SIGNS MUST MEET CHAPTER 134 OF
THE CITY CODE OF ORDINANCES AND BE
APPROVED UNDER A SEPARATE PERMIT
ISSUED BY THE BUILDING DEPARTMENT

4" DIAGONAL YELLOW
STRIPING AT 48" O.C., TYP.

CONCRETE SIDEWALK, TYP.
REFER TO DETAILS ON C-9.1

8' WIDE ASPHALT PATH, TYP.
REFER TO DETAILS ON C-9.1

ROCHESTER ROAD
120 FT. WIDE - PUBLIC
(MDOJ JURISDICTION)

18"x6" CONCRETE CURB
AND GUTTER, TYP. REFER
TO DETAIL ON SHEET C-9.1

30" WIDE F-5 CURB AND GUTTER.
REFER TO M.D.O.T. DETAIL R-30
ON CONSTRUCTION PLANS

EXISTING CONCRETE SIDEWALK,
SIDEWALK RAMPS AND DETECTABLE
WARNING TO REMAIN AT ROAD
INTERSECTION, AS SHOWN.

SW CORNER SECTION 14, T.03N., R.11E
CITY OF ROCHESTER HILLS
OAKLAND COUNTY, MI
REMON IN MON BOX

24"x6" CONCRETE CURB
AND GUTTER, TYP. REFER
TO DETAIL ON SHEET C-9.1

CONCRETE SIDEWALK, TYP.
REFER TO DETAILS ON C-9.1

8' WIDE ASPHALT PATH, TYP.
REFER TO DETAILS ON C-9.1

MATCH EX. CURB TYPE AND WIDTH
WITH NEW CURBS TO CLOSE
EXISTING DRIVE OPENINGS. THE NEW
CURBS TO EXISTING USING EPOXY
COATED #4 BARS PER R.C.O.C.

CONCRETE DRIVE APPROACH,
REFER TO DETAILS ON C-9.1

9" DEEP STRENGTH ASPHALT
PAVEMENT REPAIR AFTER
STORM SEWER CONNECTION
REFER TO DETAILS ON C-9.1

24"x6" CONCRETE CURB
AND GUTTER, TYP. REFER
TO DETAIL ON SHEET C-9.1

24" WIDE BUTT JOINT AS REQUIRED
BY R.C.O.C. FIELD INSPECTOR.
REFER TO DETAIL ON C-9.1

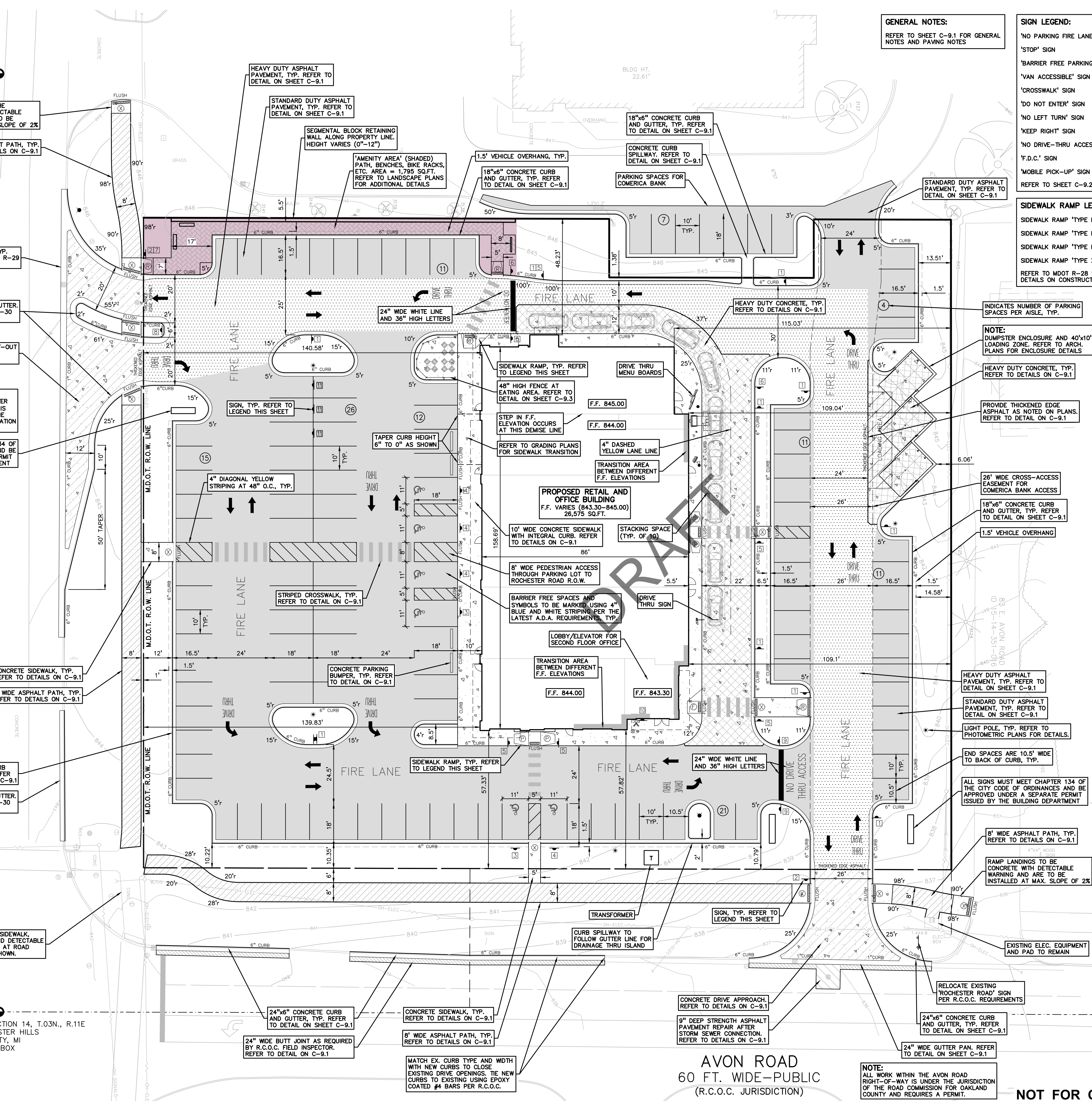

GENERAL NOTES:
REFER TO SHEET C-9.1 FOR GENERAL
NOTES AND PAVING NOTES

- SIGN LEGEND:**
- 1 'NO PARKING FIRE LANE' SIGN
 - 2 'STOP' SIGN
 - 3 'BARRIER FREE PARKING' SIGN
 - 4 'VAN ACCESSIBLE' SIGN
 - 5 'CROSSWALK' SIGN
 - 6 'DO NOT ENTER' SIGN
 - 7 'NO LEFT TURN' SIGN
 - 8 'KEEP RIGHT' SIGN
 - 9 'NO DRIVE-THRU ACCESS' SIGN
 - 10 'F.D.C.' SIGN
 - 11 'MOBILE PICK-UP' SIGN
- REFER TO SHEET C-9.2 FOR SIGN DETAILS

- SIDEWALK RAMP LEGEND:**
- 12 SIDEWALK RAMP 'TYPE R'
 - 13 SIDEWALK RAMP 'TYPE P'
 - 14 SIDEWALK RAMP 'TYPE RF'
 - 15 SIDEWALK RAMP 'TYPE X'
- REFER TO MDOJ R-28 STANDARD RAMP
DETAILS ON CONSTRUCTION PLANS



- LEGEND**
- IRON FOUND
 - IRON SET
 - NAIL FOUND
 - NAIL & CAP SET
 - BRASS PLUG SET
 - MONUMENT FOUND
 - MONUMENT SET
 - RECORDED
 - M MEASURED
 - C CALCULATED
 - SEC CORNER FOUND
 - SEC CORNER SET
 - MEASURED
 - CALCULATED

- REFERENCE DRAWINGS**
- WATER MAIN
 - SANITARY SEWER
 - STORM SEWER
 - ELECTRIC
 - TELEPHONE
 - GAS
 - PETROLEUM
 - CITY
 - FLOOD PLAN
 - OTHER ROAD PLANS, VARIOUS PROJECTS
 - BOUNDARY TOPOGRAPHIC SURVEY, COMERICA BANK, NF #1448, DATED 12/21/10
 - OTHER
 - PARTIAL GRADING/UTILITY PLAN, COMERICA BANK, UNDATED

PEA GROUP
t: 844.813.2949
www.peagroup.com

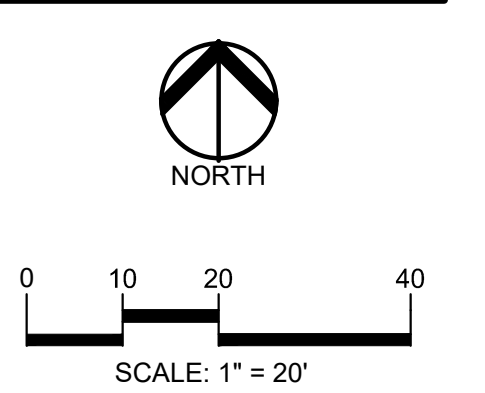

811 Know what's below. Call before you dig.

CAUTION!!
THE LOCATION AND ELEVATIONS OF EXISTING UNDERGROUND
UTILITIES AS SHOWN ON THIS DRAWING ARE ONLY
APPROXIMATE. NO GUARANTEE AS TO ACCURACY THEREOF.
THE CONTRACTOR SHALL EXERCISE RESPONSIBILITY FOR
DETERMINING THE EXACT UTILITY LOCATIONS AND ELEVATIONS
PRIOR TO THE START OF CONSTRUCTION.

SITE DATA TABLE:

SITE AREA: 2.033 ACRES (88,539 SF)

ZONING: B-2 GENERAL BUSINESS WITH FB-3 FLEX BUSINESS OVERLAY
(GAS STATION PROPERTY IS B-5 AUTOMOTIVE WITH FB-3 FLEX
BUSINESS OVERLAY)

PROPOSED USE: MIXED USE RETAIL/RESTAURANT/OFFICE BUILDING

- RESTAURANT WITH DRIVE THRU = 2,288 SF
- RETAIL = 4,278 SF
- RESTAURANT = 4,053 SF
- OFFICE = 10,943 SF
- CIRCULATION = 3,013 SF
- TOTAL BUILDING AREA = 26,575 SF

BUILDING INFORMATION:

- MAXIMUM ALLOWABLE BUILDING HEIGHT = 45 FEET (3 STORIES)
- PROPOSED BUILDING HEIGHT = 2-STORIES (37'-6" HIGH)
- BUILDING FOOTPRINT AREA = 13,346 SF
- BUILDING LOT COVERAGE = (13,346 SF / 88,539 SF) x 100 = 15.1%
- MINIMUM BUILDING FRONTAGE BUILT-TO-AREA:
159.36' FAÇADE WIDTH/270' ROCHESTER ROAD FRONTAGE = 58% (40% MIN. REQ.)

SETBACK REQUIREMENTS:

REQUIRED	PROVIDED
FRONT SETBACK (WEST): 50'	139.83'
FRONT SETBACK (SOUTH): 50'	57.33'
SIDE SETBACK (NORTH): 0'	48.23'
REAR SETBACK (EAST): 50'	109.04'
PARKING SETBACK (WEST): 10'	12.0'
PARKING SETBACK (SOUTH): 10'	10.22'

REQUIRED PARKING FOR PROPOSED DEVELOPMENT:

- MINIMUM 1 SPACE PER 400 SF OF GROSS FLOOR AREA (26,575/400) = 67 SPACES
- MAXIMUM PARKING IS 200% OF MINIMUM (67 x 2) = 134 SPACES

PARKING PROVIDED:

- TOTAL PARKING SPACES PROPOSED = 111 SPACES (INC. 6 H/C SPACES)
- (DOES NOT INCLUDE 7 SPACES FOR COMERICA BANK)

OUTDOOR AMENITY:

- REQUIRED AMENITY SPACE IS 2% OF TOTAL SITE AREA (88,539 x 0.02) = 1,771 SF
- AMENITY SPACE PROVIDED = 1,795 SF

ROAD COMMISSION FOR OAKLAND COUNTY (R.C.O.C.) NOTES:

1. PROPER SIGNING IS REQUIRED PRIOR TO ANY WORK STARTING WITHIN THE ROAD RIGHT-OF-WAY.
2. LANE CLOSURES WILL BE RESTRICTED TO 9AM - 3PM MONDAY THROUGH FRIDAY.
3. MAINTAIN TWO-WAY TRAFFIC AT ALL TIMES.
4. PROPOSED CURBS SHOULD MATCH EXISTING CURBS AND WILL BE TIED TO EXISTING CURBS USING EPOXY-COATED #4 BAR.
5. A FULL-DEPTH SAWCUT AND/OR MILLED BUTT-JOINT WILL BE REQUIRED AT THE AVON ROAD DRIVE APPROACH PER THE R.C.O.C. FIELD INSPECTOR.
6. ALL FIXED OBJECTS WITHIN 5 FEET OF BACK OF CURB WILL BE REMOVED OR RELOCATED PRIOR TO EXCAVATION.
7. ROADWAYS SHALL BE KEPT CLEAN OF DIRT AND DEBRIS.
8. ALL EXCAVATIONS WITHIN A 1:1 INFLUENCE OF THE ROADWAY WILL REQUIRE M.D.O.T. CLASS II BACKFILL COMPACTED TO 95% MAXIMUM DENSITY.

CLIENT
ROCHESTER AVON PARTNERS, LLC
251 EAST MERRILL STREET, SUITE #205
BIRMINGHAM, MICHIGAN, 48009

PROJECT TITLE
RETAIL REDEVELOPMENT
N.E.C. ROCHESTER ROAD & AVON ROAD
CITY OF ROCHESTER HILLS, OAKLAND COUNTY, MI

REVISIONS

ORIGINAL ISSUE DATE:
MAY 10, 2021

DRAWING TITLE
SITE PLAN

PEA JOB NO. 2019-007
P.M. RLS
DN. PB
DES. PB

DRAWING NUMBER:
C-3.0

AVON ROAD
60 FT. WIDE - PUBLIC
(R.C.O.C. JURISDICTION)

NOT FOR CONSTRUCTION

NOTE:
ALL WORK WITHIN THE AVON ROAD
RIGHT-OF-WAY IS UNDER THE JURISDICTION
OF THE ROAD COMMISSION FOR OAKLAND
COUNTY AND REQUIRES A PERMIT.

XREF: S:\PROJECTS\2019\2019-007\DWG\TOPBASE-19007.dwg
XREF: S:\PROJECTS\2019\2019-007\DWG\SITE PLANS\CEASE-19007.dwg
XREF: S:\PROJECTS\2019\2019-007\DWG\SITE PLANS\BLK-19007.dwg

issued for:
 OWNER REVIEW: 11 SEPT. 2020
 OWNER REVIEW: 01 FEB. 2021
 OWNER REVIEW: 10 FEB. 2021
 OWNER REVIEW: 11 FEB. 2021
 OWNER REVIEW: 08 MAR. 2021
 OWNER REVIEW: 19 APR. 2021
 OWNER REVIEW: 20 APR. 2021
 OWNER REVIEW: 22 APR. 2021
 SITE PLAN REVIEW: 05 MAY 2021

project:

Proposed
Commercial Development

NEC Rochester Rd. & Avon Rd.
 Rochester Hills, Michigan



32500 TELEGRAPH ROAD
 SUITE 250
 BINGHAM FARMS, MICHIGAN
 48025-2404
 PH 248.540.7700 FX 248.540.2710
 www.rogvoy.com



drawing:

**First Level
 Floor Plan**

DO NOT SCALE DRAWING

issue date:
 drawn: KL
 checked: MD
 approved: MD

file number: 19026

sheet:

A-1

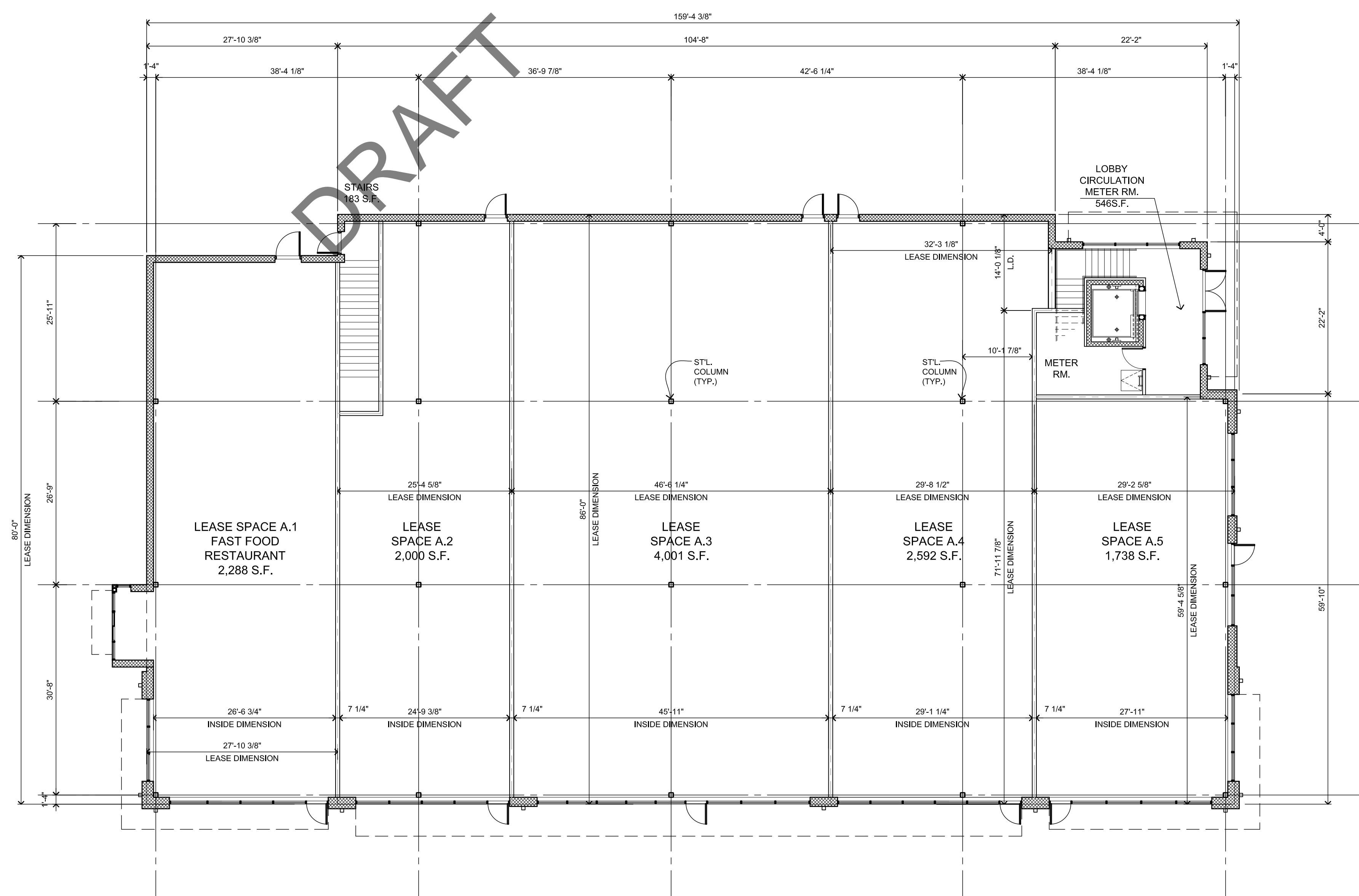

1st Level Floor Plan

GFA : 13,348 S.F.
 GLA : 12,619 S.F.

Scale: 3/32"=1'-0"

issued for:
 OWNER REVIEW: 11 SEPT. 2020
 OWNER REVIEW: 01 FEB. 2021
 OWNER REVIEW: 11 FEB. 2021
 SITE PLAN REVIEW: 05 MAY 2021

project:

Proposed
Commercial Development
 NEC Rochester Rd. & Avon Rd.
 Rochester Hills, Michigan



32500 TELEGRAPH ROAD
 SUITE 250
 BINGHAM FARMS, MICHIGAN
 48025-2404
 PH 248.540.7700 FX 248.540.2710
 www.rogvoy.com



drawing:
**Second Level
 Floor Plan**

DO NOT SCALE DRAWING

issue date:
 drawn: KL
 checked: MD
 approved: MD

file number: **19026**

sheet:

A-2

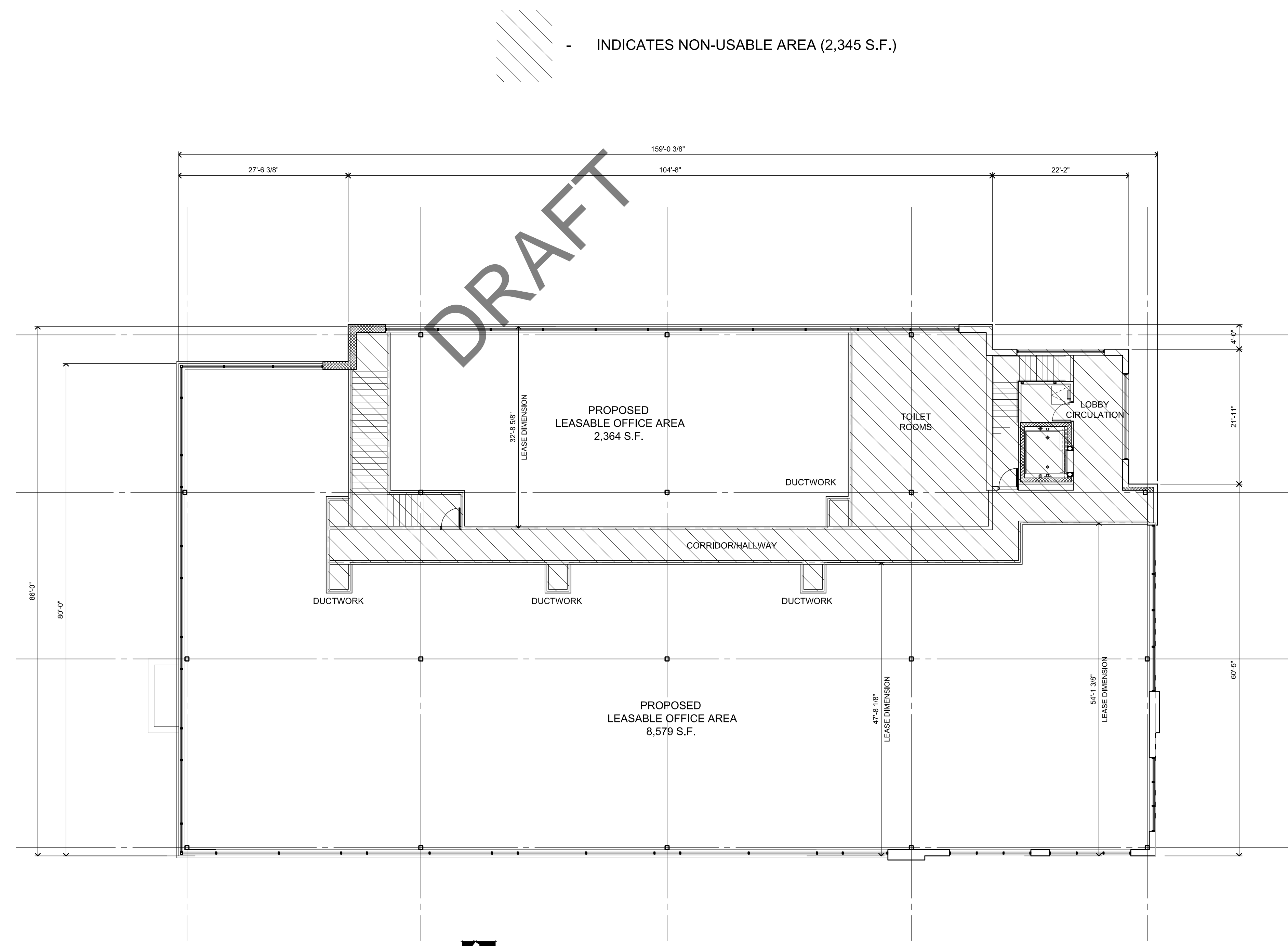

2nd Level Floor Plan
 GFA : 13,288 S.F.
 GLA : 10,943 S.F.
 Scale: 3/32"=1'-0"

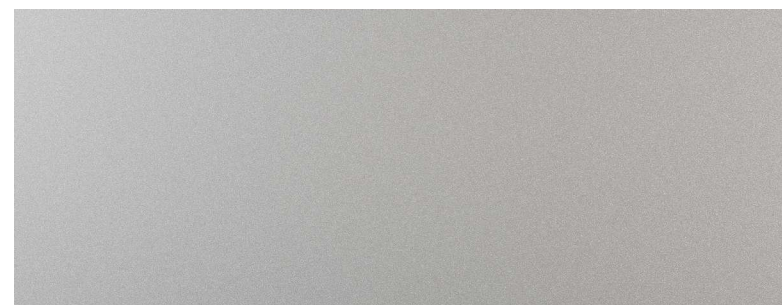

- ALUMINUM WALL PANEL : ALUCABOND COLOR: 'CHAMPAGNE METALLIC'



- BRICK : ALUCABOND COLOR: BRICK TECH ENDICOTT COLOR: 'MANGANESE IRON SPOT'

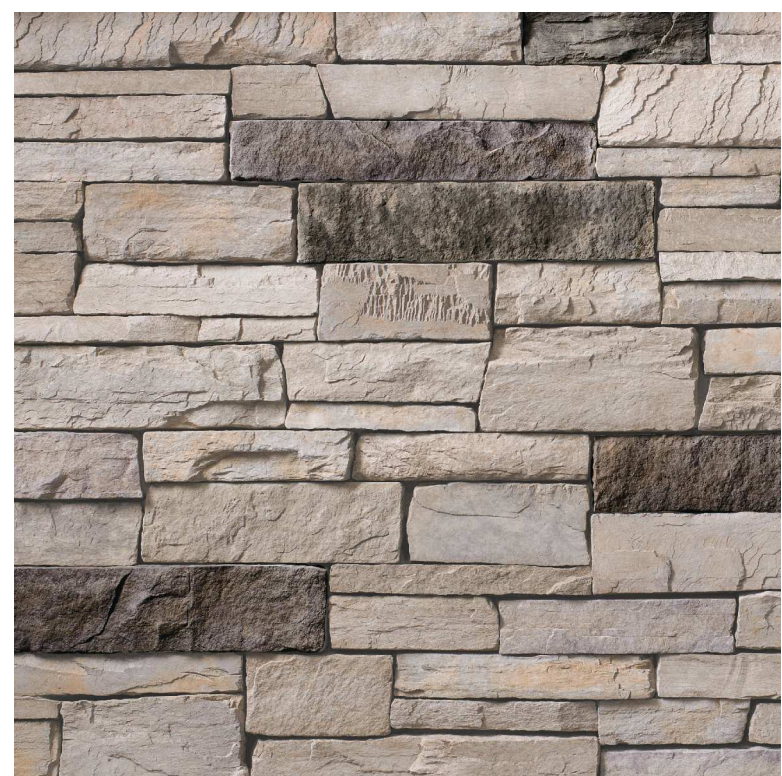

- STONE : CULTURED STONE COUNTRY LEDGESTONE COLOR: 'ASHFALL'

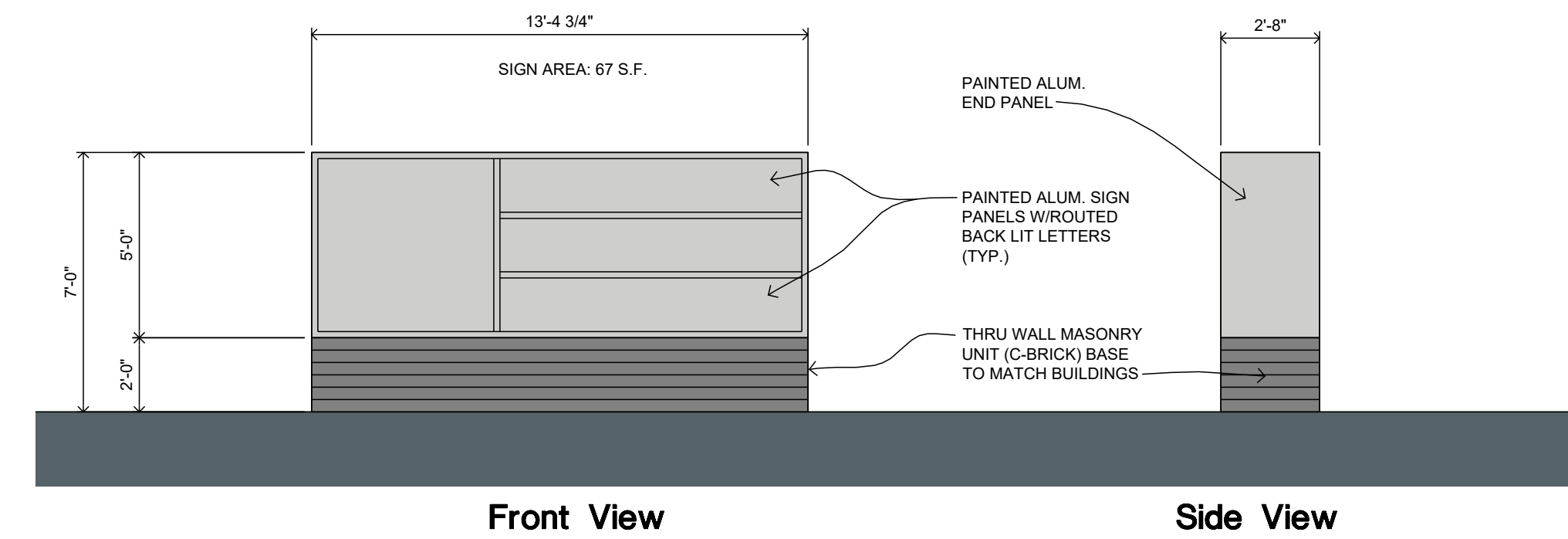

Monument Sign - Avon Rd.

Scale: 1/4"=1'-0"

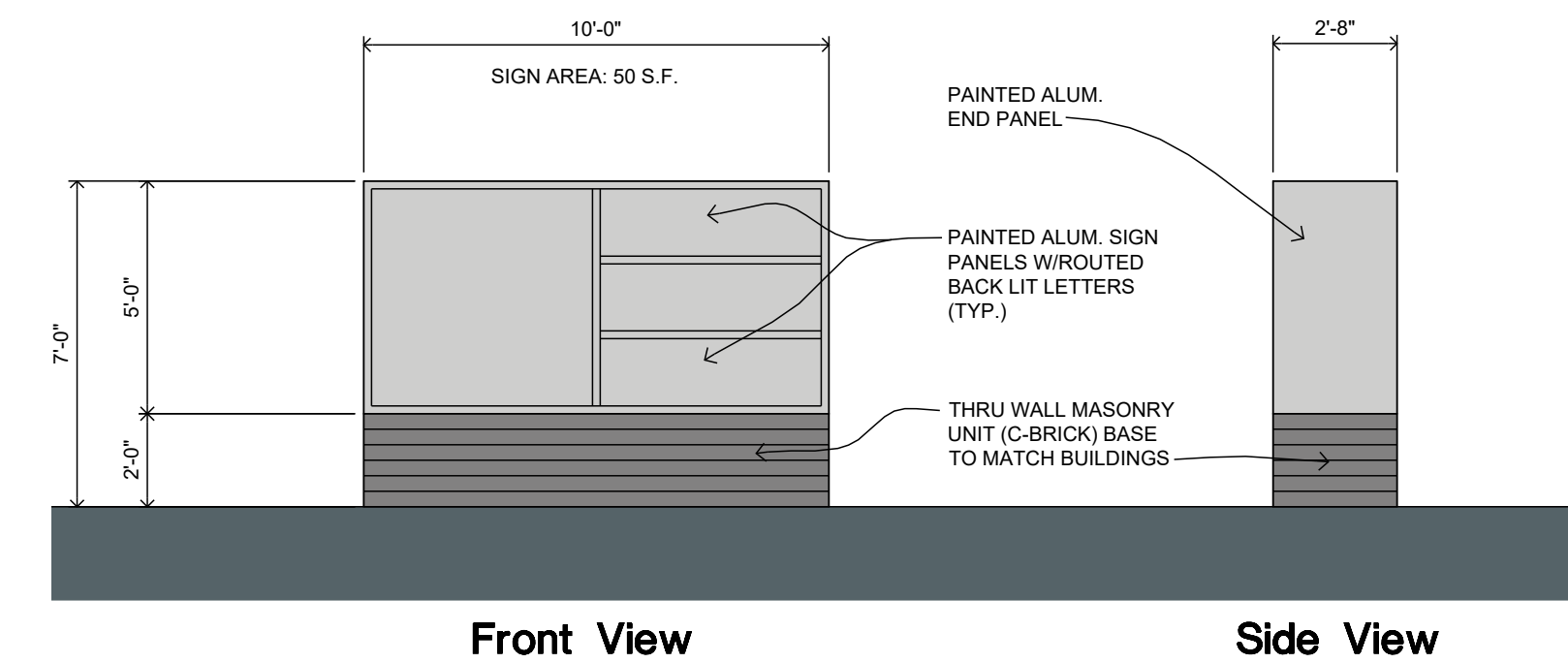

Monument Sign - Rochester Rd.

Scale: 1/4"=1'-0"

DRAFT

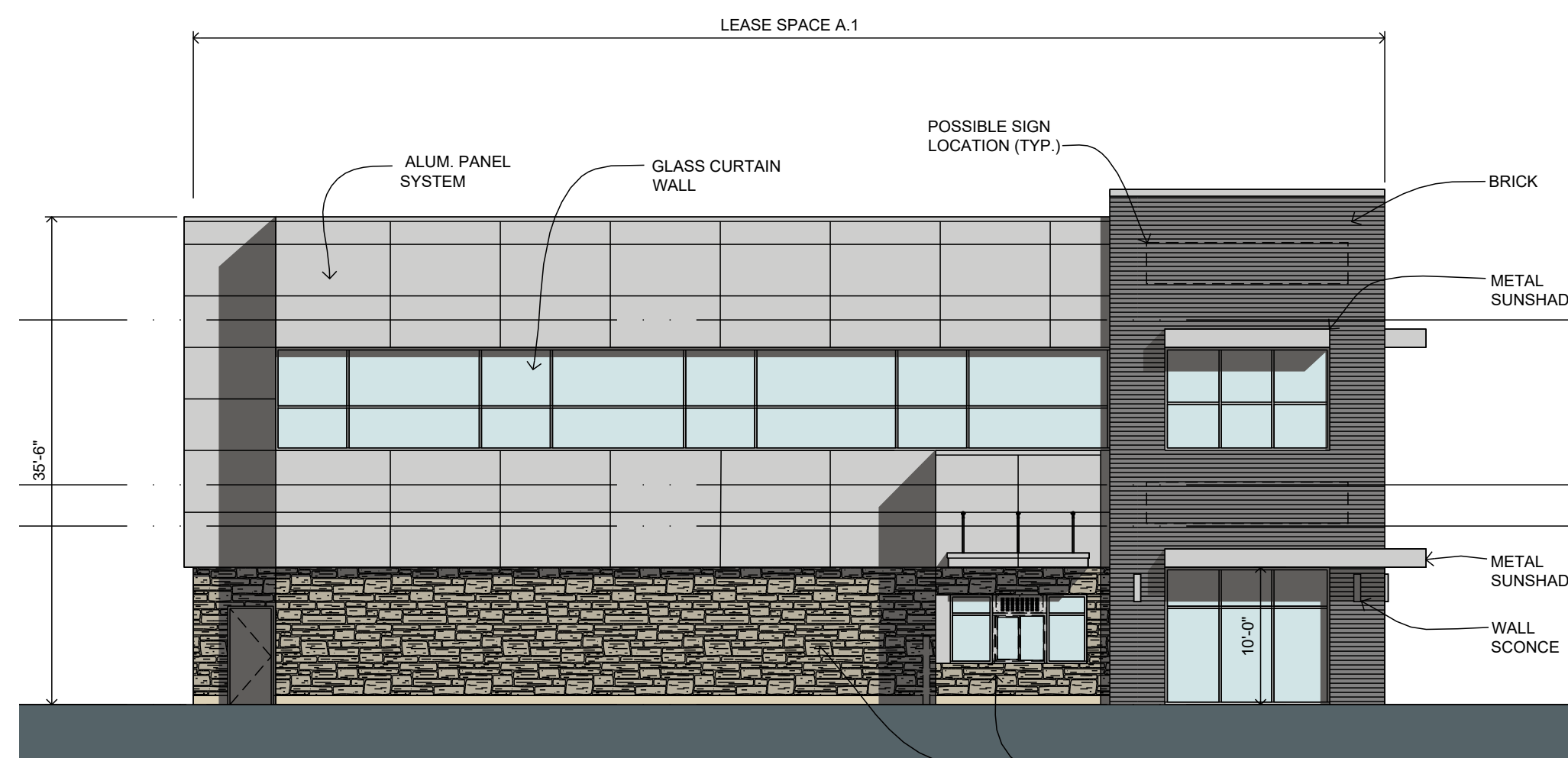

North Elevation

Scale: 3/32"=1'-0"

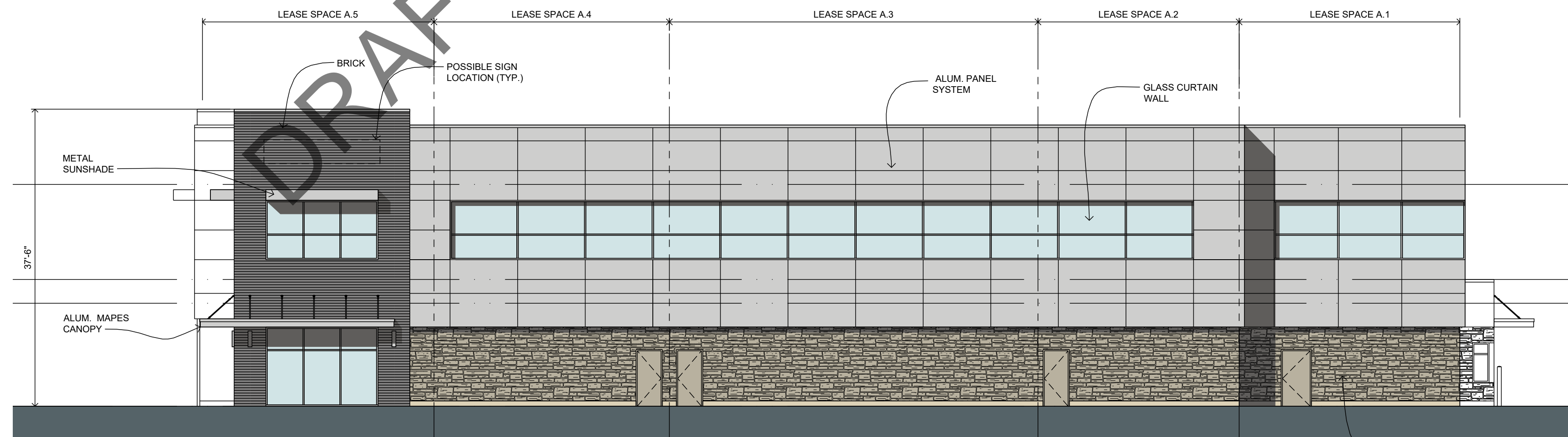

East Elevation

Scale: 3/32"=1'-0"

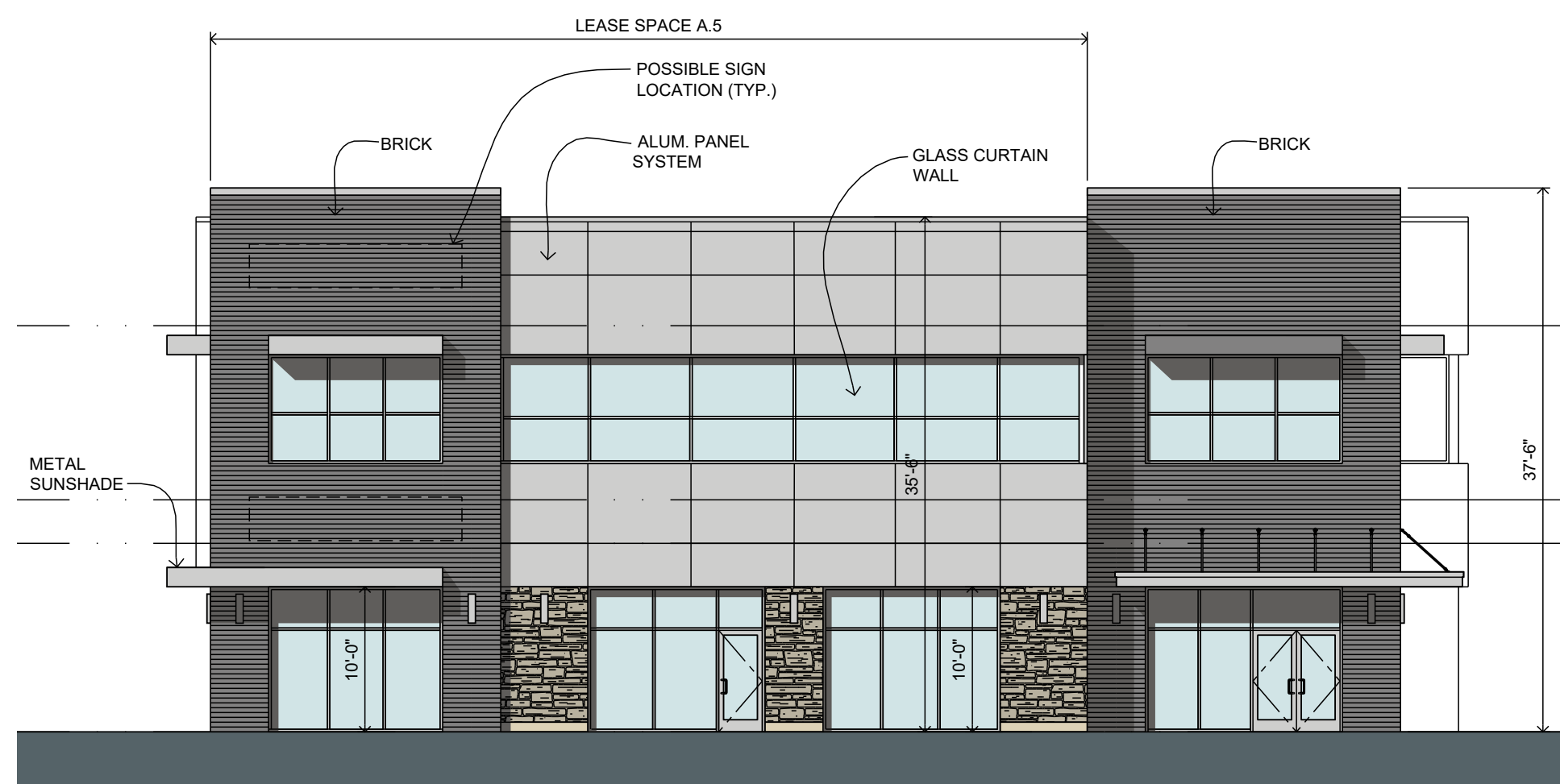

South Elevation

Scale: 3/32"=1'-0"

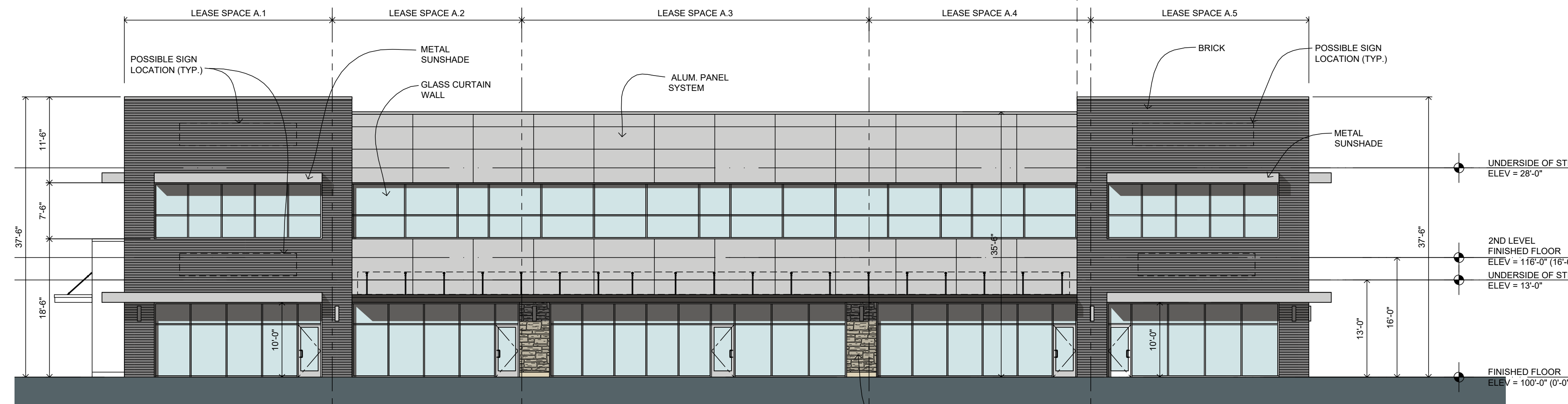

West Elevation

Scale: 3/32"=1'-0"

project:

Proposed
Commercial Development
 NEC Rochester Rd. & Avon Rd.
 Rochester Hills, Michigan



32500 TELEGRAPH ROAD
 SUITE 250
 BINGHAM FARMS, MICHIGAN
 48025-2404
 PH 248.540.7700 FX 248.540.2710
 www.rogvooy.com



drawing:
Conceptual Bldg. Elevations

DO NOT SCALE DRAWING

issue date:
 drawn: KL
 checked: MD
 approved: MD

file number: 19026

sheet:

Attachment D

DRAFT



Documentation of Eligibility

2019 Phase I Environmental Site Assessment (ESA) - PM Environmental, Inc. (PM)

PM conducted a Phase I ESA for the parcels located at 945 and 975 South Rochester Road on September 10, 2019. At the time of the Phase I, the subject property was occupied by the existing gasoline station and convenience store. There were no service operations observed during the Phase I.

Standard and historical sources documented the subject property consisted of agricultural and vacant land from at least 1937 until between 1964 and 1967 when the current building was constructed in the northeastern portion. The building was utilized for gasoline service station operations from at least 1967 until 1999, when the building was renovated into the current convenience store and gasoline dispensing station. A canopy was constructed in the western portion in 1980, which was replaced with the current canopy in 1997. The property has operated as a gasoline dispensing station since 1999.

PM reviewed the following reports pertaining to previous environmental investigations completed at the subject property.

Name of Report	Date of Report	Company that Prepared Report
Final Assessment Report	4-8-1997	EnecoTech Midwest, Inc. (ETM)
Groundwater Monitoring Report	7-28-1997	ETM
Groundwater Monitoring Report	10-8-1997	ETM
Groundwater Monitoring Report	1-22-2003	Groundwater & Environmental Services, Inc. (GES)
Closure Report	8-27-2004	GES
Phase I ESA	2-22-2005	AKT Peerless Environmental Services (AKT)
Subsurface Investigation Report	3-31-2005	AKT
Underground Storage Tank System Assessment and Closure Report	7-17-2008	Midwest Environmental Consulting Group (MECG)

The subject property, 975 South Rochester Road, is a closed Leaking Underground Storage Tank (LUST) site with two releases reported on April 8, 1996 (Leak ID: C-0214-96) and April 24, 1996 (Leak ID: C-0252-96) which were granted a Tier I Commercial III Restricted Closure on February 17, 2005.

Various site assessment activities were conducted between 1997 and 2008 which included the removal of several underground storage tanks (USTs) along with the excavation of approximately 40 cubic yards of soil; soil and groundwater sampling activities; and groundwater monitoring activities. Analytical results following the August 2004 Closure Report and March 2005 Subsurface Investigation Report documents groundwater sampling events which exceeded the current Part 213 Risk Based Screening Levels (RBSLs), and the current Recommended Interim Action Screening Levels (RIASLs) indicating a vapor intrusion concern may be present. Additionally, the March 2005 site investigation activities included a ground penetrating radar (GPR) survey to assess the potential for orphan USTs. The report indicates the GPR survey did not identify any anomalies consistent with the presence of orphan USTs, however, the GPR survey was not included within the report reviewed. Therefore, PM identified the lack of the GPR survey as a significant deficiency and the potential for orphan USTs as a recognized environmental condition (REC). Furthermore, the site investigation activities completed between 1997 and 2008 did not collect any groundwater or soil samples within the footprint of the subject

building. Therefore, the long-term historical automotive service operations have not been adequately assessed and was identified as a REC.

Based on the cumulative 1997-2008 analytical results, concentrations of various gasoline volatile organic compounds (VOCs) were identified in soil and groundwater exceeding the current Part 213 Residential and Nonresidential Risk Based Screening Levels (RBSLs). In addition, contaminant concentrations may be indicative of a vapor intrusion concern based on the separation distance and lack of delineation of contamination towards the subject building. Based on these analytical results and its closed LUST status, the subject property meets the definition of a "property," in accordance with Part 213 of P.A. 451 of the Michigan Natural Resources Environmental Protection Act (NREPA), as amended, which represents a REC).

The following onsite recognized RECs were identified in the Phase I ESA:

- The subject property, 975 South Rochester Road, operated as a gasoline dispensing station since between 1964 and 1967. Additionally, the subject property is a closed LUST site with two reported releases in 1996. The releases were granted a Restricted Tier I Commercial III Closure in February 2005. Review of previous site assessment activities documents that soil and groundwater contamination remains on-site above the current Part 213 RBSLs. In addition, contaminant concentrations may be indicative of a vapor intrusion concern. Based on these analytical results and its closed LUST status, the subject property meets the definition of a "property," in accordance with Part 213 of P.A. 451 of the Michigan Natural Resources Environmental Protection Act (NREPA), as amended.
- Review of previous site investigations document the current UST system was last assessed in August 2008. The subject property has continued to operate as a gasoline dispensing station with the current layout since August 2008 with no site assessment activities since that time. The potential exists that a new release has occurred from the current UST system and/or fuel dispensers.
- The subject property, 975 South Rochester Road, operated as a gasoline service station from at least 1967 until 1999. Historical interior waste streams associated with the former service operations would have consisted of general hazardous substances and/or petroleum products. The previous site investigation activates did not adequately assess all areas of the former gasoline service station. A significant portion of this time period preceded major environmental regulations and current waste management and disposal procedures. The historical waste management practices associated with the former gasoline service station operations are unknown and may be a source of subsurface contamination.
- The previous site investigation activates did not adequately assess the former gasoline service station area, which likely contained in-ground hoists. In-ground hoists have an underground reservoir for hydraulic fluids, which can contain polychlorinated biphenyls (PCBs). The potential exists that a release occurred from the former hydraulic hoist system and/or underground reservoir.
- The subject property, 975 South Rochester Road, operated as a gasoline dispensing and/or service station since between 1964 and 1967. PM was unable to obtain information

regarding the UST systems prior to and between 1967 and 1972. Therefore, additional fueling and/or new or waste oil USTs may have historically been present. Further, records indicate the subject buildings were connected to natural gas in 1978 and 1980, and the 975 South Rochester Road subject building likely utilized a fuel oil UST prior to natural gas connection. The potential exists for orphan USTs to be present on the property and/or for a release to have occurred.

A controlled recognized environmental condition (CREC), as defined in the ASTM Standard, is a REC resulting from a past release of hazardous substances or petroleum products that has been addressed to the satisfaction of the applicable regulatory authority with hazardous substances or petroleum products allowed to remain in place subject to the implementation of required controls. The following CREC was identified during completion of this Phase I ESA:

- The subject property located at 975 South Rochester Road is a closed LUST site with two releases reported in 1996. The release was granted a Restricted Tier I Commercial III Closure in February 2005. Review of previous site assessment activities documents that soil and groundwater contamination remains on-site above the current Part 213 Residential and Nonresidential RBSLs. In addition, contaminant concentrations may be indicative of a vapor intrusion concern. A deed restriction was recorded in 2004 that eliminates the use of groundwater for any purpose on the subject property, and any future change in the land use may necessitate further evaluation of potential risks to the public health, safety, and welfare to the environment. Based on the closed LUST status and restrictions associated with the LUST closure, PM has identified the closed LUST status as a CREC.

2019 Baseline Environmental Assessment (BEA) - PM Environmental, Inc.

The BEA was prepared and submitted for the parcel located at 975 S. South Rochester Road on behalf of Rochester Avon Partners, LLC on September 10, 2019, based on the available data documented in the Phase I. Based upon documented soil and groundwater exceedances of the Part 213 Residential and Nonresidential DWP/DW and GSIP/GSI RBSLs, and the closed LUST status, the subject property is a "Property" under Part 213 of P.A. 451, as amended and the rules promulgated thereunder.

2019 Documentation of Due Care Compliance (DDCC) - PM Environmental, Inc.

A DDCC report was prepared for the 975 S. Rochester Road parcel on November 19, 2019. The report documented the prior investigations and indicated that current and future use of the property would remain the same through January 2020. At that time, borrower intends to redevelop the property for commercial purposes. The subject property is currently zoned B-5: Automotive Business. The current and intended use and zoning is consistent with Nonresidential property use as defined under Part 213.

The DDCC took into account the following obligations:

- (a) Undertake measures as are necessary to prevent exacerbation.
- (b) Exercise due care by undertaking corrective action necessary to mitigate unacceptable exposure to regulated substances, mitigate fire and explosion hazards due to regulated

substances, and allow for the intended use of the property in a manner that protects the public health and safety.

- (c) Take reasonable precautions against the reasonably foreseeable acts or omissions of a third party and the consequences that foreseeably could result from those acts or omissions.
- (d) Provide reasonable cooperation, assistance, and access to the persons that are authorized to conduct corrective action activities at the property, including the cooperation and access necessary for the installation, integrity, operation, and maintenance of any complete or partial corrective action activity at the property.
- (e) Comply with any land use or resources use restrictions established or relied on in connection with the corrective action activities at the property.
- (f) Not impede the effectiveness or integrity of any land use or resource use restriction employed at the property in connection with corrective action activities.

Additional site evaluations were completed to support the DDCC. The scope of work included a ground penetrating radar (GPR) survey, six soil borings (SB-1 through SB-6), installing four temporary monitoring wells (TMW-3 through TMW-6) and collecting eight soil samples and four groundwater samples for laboratory analysis. The soil and groundwater samples were submitted for laboratory analysis of VOCs, polynuclear aromatics (PNAs), polychlorinated biphenyls, (PCBs), and metals (cadmium, chromium, and lead), or some combination thereof.

No anomalies consistent with the presence of orphan USTs or inground hoists were identified during the completion of the GPR survey. However, PM confirmed the presence of the previously closed in place USTs consisting of two 10,000-gallon gasoline UST and one 6,000-gallon gasoline UST in 2008 located south of the subject building.

The results of the additional evaluation indicated that concentrations of VOCs and PNAs were present in soil above one or more of Drinking Water Protection (DWP), Groundwater Surface Water Interface Protection (GSIP), Soil Volatilization to Indoor Air Inhalation (SVII) and Direct Content (DC) criteria at three of the six boring locations.

Concentrations of VOCs, PNAs and metals were detected in groundwater exceeding one or more of DWP and GSIP criteria in two of the four samples analyzed.

As such, the following response actions were defined:

Confirmed LUST Release

Based on the results of PM's September 2019 site investigation, a confirmed release (REL-0223-19) was reported for the subject property for Safeway Acquisitions Group LLC (i.e., the current operator) on October 3, 2019.

Notices

Due to the presence of contamination exceeding the Part 213 Nonresidential DC RBSLs, Light Non-Aqueous Phase Liquid (LNAPL) SVII and DC screening levels, written notices have been provided to easement holders of record, utility franchise holders of record, and the owners and/or operators of all public utilities that serve the subject property.

Preventing Building Occupant Vapor Intrusion Exposures

Concentrations of gasoline VOCs were identified in soil samples collected from the subject property in 2005 and 2019 above the Non-Aqueous Phase Liquid (NAPL) SVII screening levels. Soil gas sampling, and/or additional vapor intrusion evaluations and/or engineering controls will be necessary to mitigate inhalation exposure risks within the current and any future proposed buildings.

Direct Contact

Concentrations of gasoline VOCs indicative of the presence of residual LNAPL were identified in the soil samples collected from the southern portion subject property in the area of the former and current gasoline UST basins depths ranging between 3.0 and 4.0 feet bgs above the LNAPL DC screening levels. Additionally, concentrations of benzo(a)pyrene were identified in soil samples collected from the northern portion of the subject property in the area of the current gasoline/diesel UST basin and/or product piping depths ranging between 3.0-4.0 feet bgs above the Part 213 DC RBSL. Therefore, surface cover (i.e. existing asphalt and concrete, concrete building slab, gravel, and areas of seeded grass and topsoil) will be maintained to prevent dermal contact with contaminated soils.

These responsive actions are sufficient to prevent unacceptable exposure to hazardous substances for subject property occupants and onsite subsurface workers and comply with the requirements of Section 21304c of the NREPA. If changes to the property use, zoning, operations, and/or layout occur, re-evaluation of potential exposure pathways and associated amendments to this report will be required. In addition, activities to comply with Section 4c obligations are still required.

The DDCC also specified general notification and material handling/disposal recommendations in the event new construction or utility work was conducted on the property.

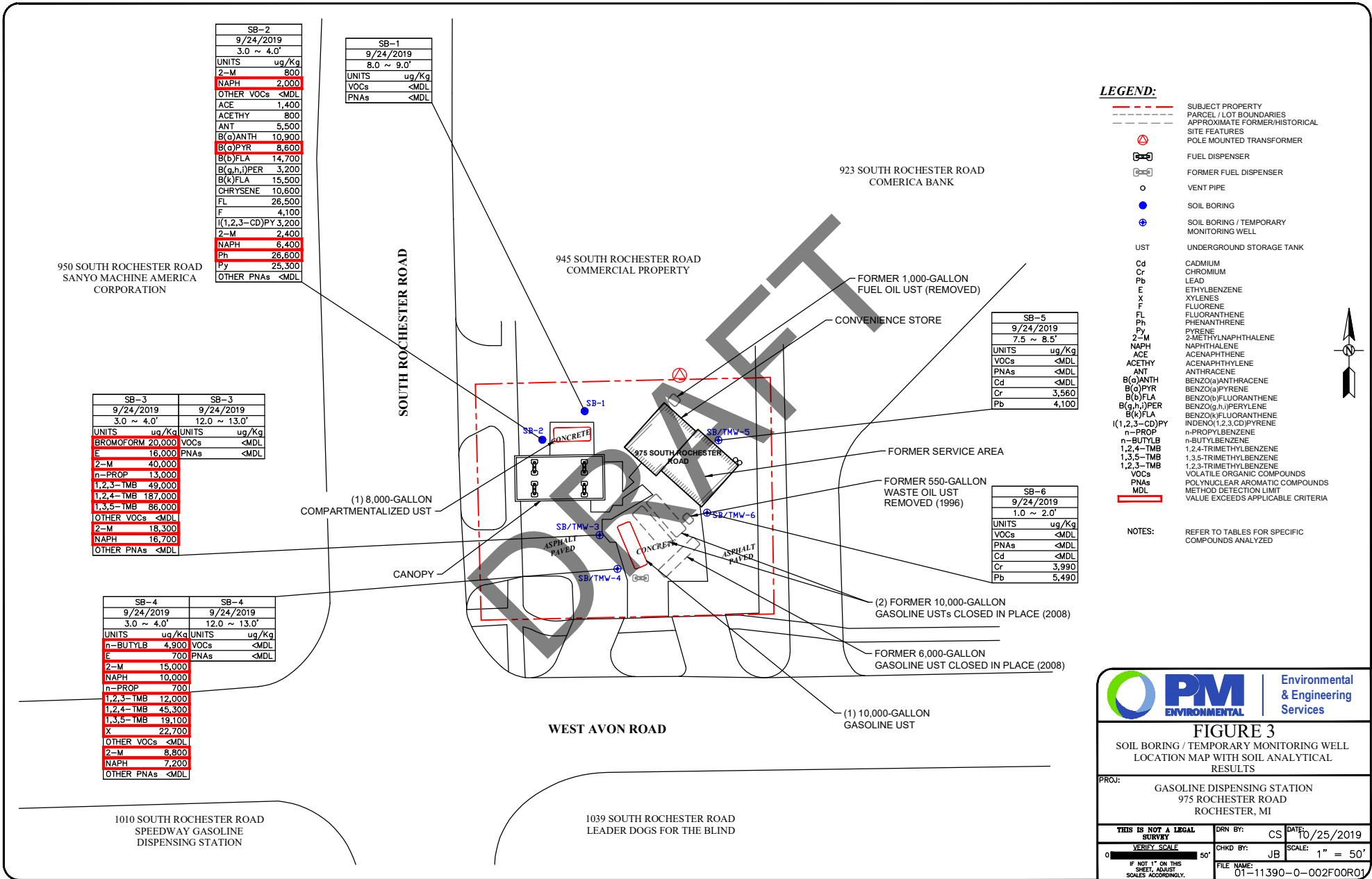

PM ENVIRONMENTAL | Environmental & Engineering Services

FIGURE 3
SOIL BORING / TEMPORARY MONITORING WELL
LOCATION MAP WITH SOIL ANALYTICAL
RESULTS

PROJ: GASOLINE DISPENSING STATION
975 ROCHESTER ROAD
ROCHESTER, MI

THIS IS NOT A LEGAL SURVEY
VERIFY SCALE

DRN BY: CS DATE: 10/25/2019
CHKD BY: JB SCALE: 1" = 50'

0 50'
IF NOT 1" ON THIS SHEET, ADJUST SCALES ACCORDINGLY.

FILE NAME: 01-11390-0-002FOOR01

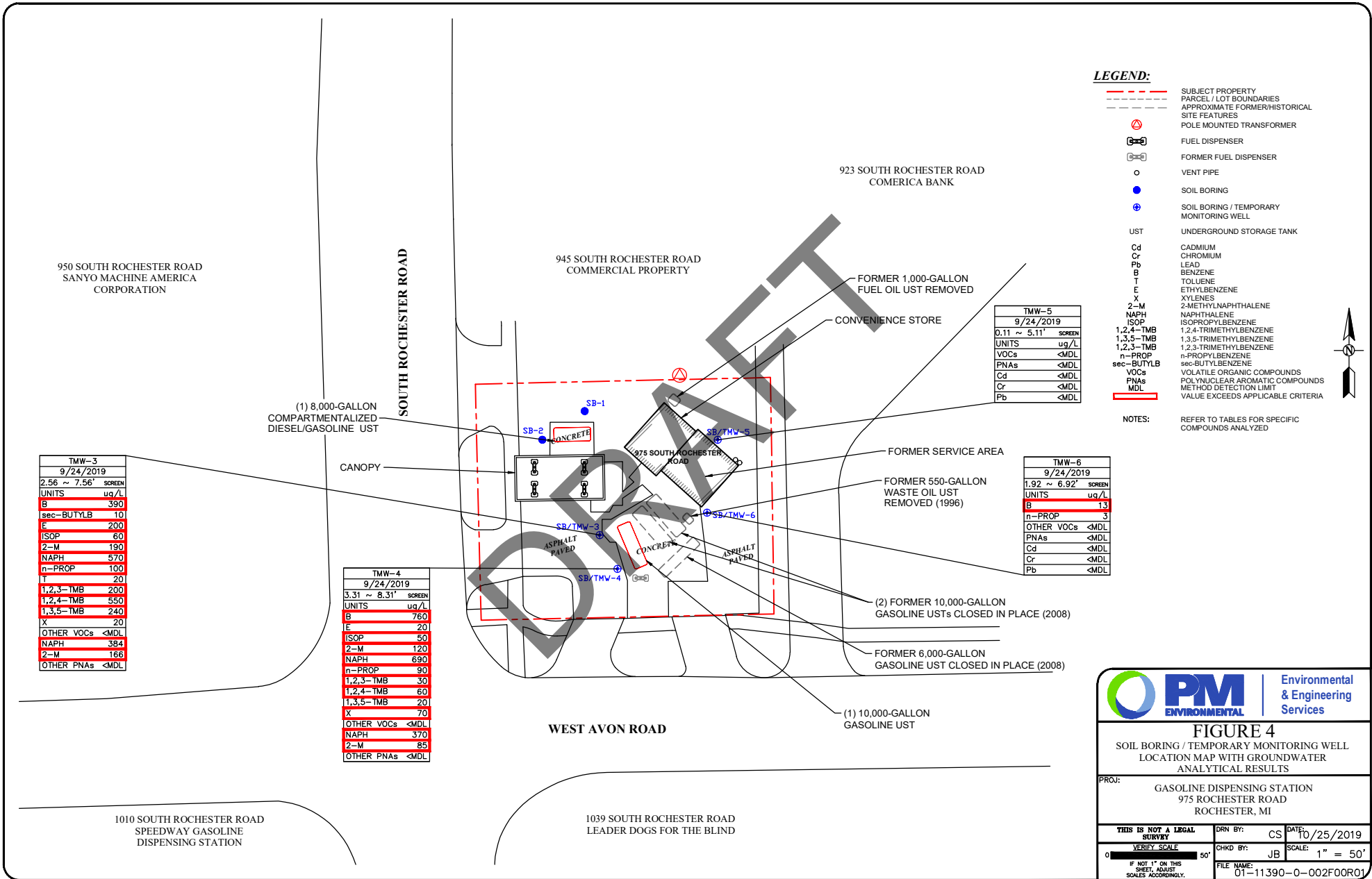

LEGEND:

- SUBJECT PROPERTY
- PARCEL / LOT BOUNDARIES
- APPROXIMATE FORMER/HISTORICAL
- SITE FEATURES
- ⊙ POLE MOUNTED TRANSFORMER
- ⊕ FUEL DISPENSER
- ⊕ FORMER FUEL DISPENSER
- VENT PIPE
- SOIL BORING
- ⊕ SOIL BORING / TEMPORARY MONITORING WELL
- UST UNDERGROUND STORAGE TANK
- Cd CADMIUM
- Cr CHROMIUM
- Pb LEAD
- B BENZENE
- T TOLUENE
- E ETHYLBENZENE
- X XYLENES
- 2-M 2-METHYLNAPHTHALENE
- NAPH NAPHTHALENE
- ISOP ISOPROPYLBENZENE
- 1,2,4-TMB 1,2,4-TRIMETHYLBENZENE
- 1,3,5-TMB 1,3,5-TRIMETHYLBENZENE
- 1,2,3-TMB 1,2,3-TRIMETHYLBENZENE
- n-PROP n-PROPYLBENZENE
- sec-BUTYLB sec-BUTYLBENZENE
- VOCs VOLATILE ORGANIC COMPOUNDS
- PNAs POLYNUCLEAR AROMATIC COMPOUNDS
- Cr <MDL METHOD DETECTION LIMIT
- Pb <MDL VALUE EXCEEDS APPLICABLE CRITERIA

NOTES: REFER TO TABLES FOR SPECIFIC COMPOUNDS ANALYZED

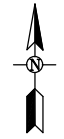

TMW-3	
9/24/2019	
2.56 ~ 7.56'	SCREEN
UNITS	ug/L
B	390
sec-BUTYLB	10
E	200
ISOP	60
2-M	190
NAPH	570
n-PROP	100
T	20
1,2,3-TMB	200
1,2,4-TMB	550
1,3,5-TMB	240
X	20
OTHER VOCs	<MDL
NAPH	384
2-M	166
OTHER PNAs	<MDL

TMW-4	
9/24/2019	
3.31 ~ 8.31'	SCREEN
UNITS	ug/L
B	760
E	20
ISOP	50
2-M	120
NAPH	690
n-PROP	90
1,2,3-TMB	30
1,2,4-TMB	60
1,3,5-TMB	20
X	70
OTHER VOCs	<MDL
NAPH	370
2-M	85
OTHER PNAs	<MDL

TMW-5	
9/24/2019	
0.11 ~ 5.11'	SCREEN
UNITS	ug/L
VOCs	<MDL
PNAs	<MDL
Cd	<MDL
Cr	<MDL
Pb	<MDL

TMW-6	
9/24/2019	
1.92 ~ 6.92'	SCREEN
UNITS	ug/L
B	13
n-PROP	3
OTHER VOCs	<MDL
PNAs	<MDL
Cd	<MDL
Cr	<MDL
Pb	<MDL



Environmental & Engineering Services

FIGURE 4

SOIL BORING / TEMPORARY MONITORING WELL
LOCATION MAP WITH GROUNDWATER ANALYTICAL RESULTS

PROJ: GASOLINE DISPENSING STATION
975 ROCHESTER ROAD
ROCHESTER, MI

THIS IS NOT A LEGAL SURVEY
VERIFY SCALE

DRN BY: CS
CHKD BY: JB

DATE: 10/25/2019
SCALE: 1" = 50'

IF NOT 1" ON THIS SHEET, ADJUST SCALES ACCORDINGLY.

FILE NAME: 01-11390-0-002F00R01

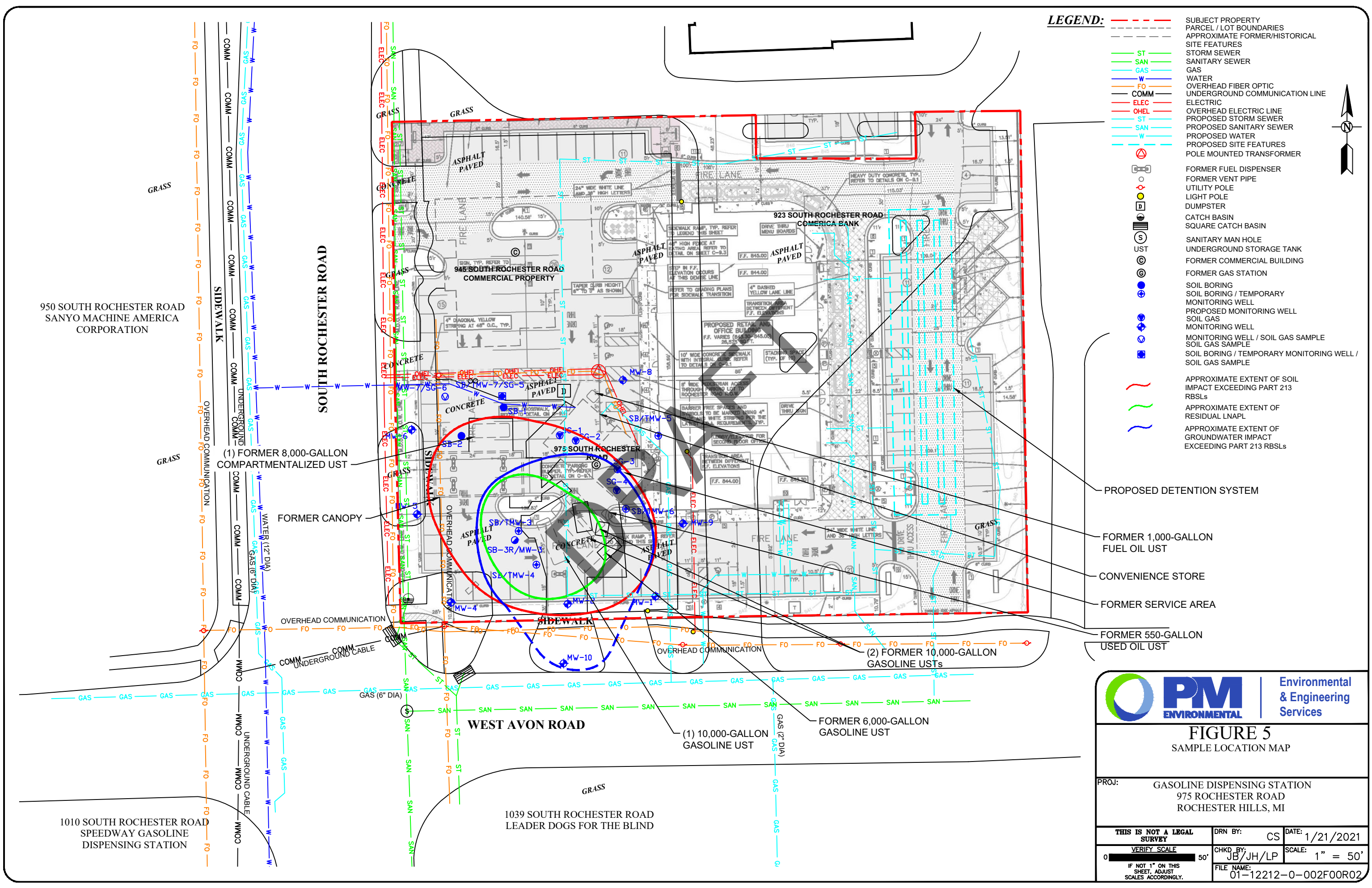

- LEGEND:**
- SUBJECT PROPERTY PARCEL / LOT BOUNDARIES
 - APPROXIMATE FORMER/HISTORICAL SITE FEATURES
 - ST STORM SEWER
 - SAN SANITARY SEWER
 - GAS GAS
 - W WATER
 - FO OVERHEAD FIBER OPTIC UNDERGROUND COMMUNICATION LINE
 - COMM UNDERGROUND COMMUNICATION LINE
 - ELEC ELECTRIC
 - OHEL OVERHEAD ELECTRIC LINE
 - ST PROPOSED STORM SEWER
 - SAN PROPOSED SANITARY SEWER
 - W PROPOSED WATER
 - PROPOSED SITE FEATURES
 - POLE MOUNTED TRANSFORMER
 - FORMER FUEL DISPENSER
 - FORMER VENT PIPE
 - UTILITY POLE
 - LIGHT POLE
 - DUMPSTER
 - CATCH BASIN
 - SQUARE CATCH BASIN
 - SANITARY MAN HOLE
 - UST UNDERGROUND STORAGE TANK
 - FORMER COMMERCIAL BUILDING
 - FORMER GAS STATION
 - SOIL BORING
 - SOIL BORING / TEMPORARY MONITORING WELL
 - PROPOSED MONITORING WELL
 - SOIL GAS MONITORING WELL
 - MONITORING WELL / SOIL GAS SAMPLE
 - SOIL GAS SAMPLE
 - SOIL BORING / TEMPORARY MONITORING WELL / SOIL GAS SAMPLE
 - APPROXIMATE EXTENT OF SOIL IMPACT EXCEEDING PART 213 RBLS
 - APPROXIMATE EXTENT OF RESIDUAL LNAPL
 - APPROXIMATE EXTENT OF GROUNDWATER IMPACT EXCEEDING PART 213 RBLS

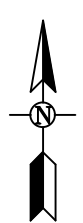

950 SOUTH ROCHESTER ROAD
SANYO MACHINE AMERICA CORPORATION

SOUTH ROCHESTER ROAD

945 SOUTH ROCHESTER ROAD
COMMERCIAL PROPERTY

923 SOUTH ROCHESTER ROAD
COMERICA BANK

975 SOUTH ROCHESTER ROAD

WEST AVON ROAD

1010 SOUTH ROCHESTER ROAD
SPEEDWAY GASOLINE DISPENSING STATION

1039 SOUTH ROCHESTER ROAD
LEADER DOGS FOR THE BLIND

(1) FORMER 8,000-GALLON
COMPARTMENTALIZED UST

FORMER CANOPY

(2) FORMER 10,000-GALLON
GASOLINE USTs

(1) 10,000-GALLON
GASOLINE UST

FORMER 6,000-GALLON
GASOLINE UST

PROPOSED DETENTION SYSTEM

FORMER 1,000-GALLON
FUEL OIL UST

CONVENIENCE STORE

FORMER SERVICE AREA

FORMER 550-GALLON
USED OIL UST



FIGURE 5
SAMPLE LOCATION MAP

PROJ: GASOLINE DISPENSING STATION
975 ROCHESTER ROAD
ROCHESTER HILLS, MI

THIS IS NOT A LEGAL SURVEY	DRN BY: CS	DATE: 1/21/2021
VERIFY SCALE	CHKD BY: JB/JH/LP	SCALE: 1" = 50'
IF NOT 1" ON THIS SHEET, ADJUST SCALES ACCORDINGLY.	FILE NAME: 01-12212-0-002F00R02	

Tables

DRAFT

Table 1: Eligible Activities Cost Estimates

Item/Activity	Total Local Only Eligible Activities
Pre-Approved Activities	
Phase I ESA	\$ 2,500
Phase II ESA/BEA/DDCC	\$ 10,800
Hazardous Materials Survey	\$ 2,025
Pre-Approved Activities Sub-Total	\$ 15,325
Department Specific Activities	
Vapor Barrier Design	\$ 20,000
Vapor Barrier Installation	\$ 60,100
Contaminated Soil Transport and Disposal	\$ 40,000
Cwater Treatment and Disposal - Groundwater Management	\$ 20,000
Frac Tank Rental - Groundwater Management	\$ 5,250
Utility Corridor Migration Barriers	\$ 5,000
Utility Gasketing	\$ 15,000
Underground Storage Tank Removal	\$ 32,000
Oversight, Sampling and Reporting by Environmental Professional	\$ 78,500
Department Specific Activities Sub-Total	\$ 275,850
Demolition	
Building Demolition Activities	\$ 60,000
Site Demolition Activities	\$ 60,000
Demolition Sub-Total	\$ 120,000
Asbestos and Lead Activities	
Asbestos Abatement	\$ 20,000
Asbestos and Lead Activities Sub-Total	\$ 20,000
Preparation of Brownfield Plan and Act 381 Workplan	
Brownfield Plan Preparation and Implementation	\$ 15,000
Brownfield Plan and Act 381 Workplan Sub-Total	\$ 15,000
Eligible Activities Sub-Total	\$ 446,175
15% Contingency*	\$ 62,378
Developer Eligible Reimbursement Total	\$ 508,553
TIF Capture for Local Brownfield Revolving Fund	\$ 162,743
Administrative Fee	\$ 35,331
State Brownfield Fund	\$ -
Total	\$ 706,627

*15% Contingency excludes preparation of Brownfield Plan and Pre-Approved Activities

Table 2
Tax Increment Revenue Capture Estimates
945 and 975 S. Rochester Road, Rochester Hills,
Oakland County, Michigan

Estimated Taxable Value (TV) Increase Rate: 1% per year

Plan Year	0	1	2	3	4	5	6	7	8	9	10	11	12	13
Calendar Year	2021	2022	2023	2024	2025	2026	2027	2028	2029	2030	2031	2032	2033	2034
*Base Taxable Value	\$ 617,020	\$ 617,020	\$ 617,020	\$ 617,020	\$ 617,020	\$ 617,020	\$ 617,020	\$ 617,020	\$ 617,020	\$ 617,020	\$ 617,020	\$ 617,020	\$ 617,020	\$ 617,020
Estimated New TV		\$ 1,728,400	\$ 1,745,684	\$ 1,763,141	\$ 1,780,772	\$ 1,798,580	\$ 1,816,566	\$ 1,834,731	\$ 1,853,079	\$ 1,871,610	\$ 1,890,326	\$ 1,909,229	\$ 1,928,321	\$ 1,947,604
Incremental Difference (New TV - Base TV)		\$ 1,111,380	\$ 1,128,664	\$ 1,146,121	\$ 1,163,752	\$ 1,181,560	\$ 1,199,546	\$ 1,217,711	\$ 1,236,059	\$ 1,254,590	\$ 1,273,306	\$ 1,292,209	\$ 1,311,301	\$ 1,330,584

State Millages	Millage Rate	0	1	2	3	4	5	6	7	8	9	10	11	12	13
State Education	6.0000	\$ 3,702	\$ 6,668	\$ 6,772	\$ 6,877	\$ 6,983	\$ 7,089	\$ 7,197	\$ 7,306	\$ 7,416	\$ 7,528	\$ 7,640	\$ 7,753	\$ 7,868	\$ 7,984
Rochester Schools Oper.	18.0000	\$ 11,106	\$ 20,005	\$ 20,316	\$ 20,630	\$ 20,948	\$ 21,268	\$ 21,592	\$ 21,919	\$ 22,249	\$ 22,583	\$ 22,920	\$ 23,260	\$ 23,603	\$ 23,951
School Total	24.0000	\$ 14,808	\$ 26,673	\$ 27,088	\$ 27,507	\$ 27,930	\$ 28,357	\$ 28,789	\$ 29,225	\$ 29,665	\$ 30,110	\$ 30,559	\$ 31,013	\$ 31,471	\$ 31,934

Local Millages	Millage Rate	0	1	2	3	4	5	6	7	8	9	10	11	12	13
Oakland County Operating	4.0200	\$ 2,480	\$ 4,468	\$ 4,537	\$ 4,607	\$ 4,678	\$ 4,750	\$ 4,822	\$ 4,895	\$ 4,969	\$ 5,043	\$ 5,119	\$ 5,195	\$ 5,271	\$ 5,349
Rochester School Sinking	1.4874	\$ 918	\$ 1,653	\$ 1,679	\$ 1,705	\$ 1,731	\$ 1,757	\$ 1,784	\$ 1,811	\$ 1,839	\$ 1,866	\$ 1,894	\$ 1,922	\$ 1,950	\$ 1,979
Oak Int SD-Alloc	0.1918	\$ 118	\$ 213	\$ 216	\$ 220	\$ 223	\$ 227	\$ 230	\$ 234	\$ 237	\$ 241	\$ 244	\$ 248	\$ 252	\$ 255
Oak Int SD-Vtd.	3.0362	\$ 1,873	\$ 3,374	\$ 3,427	\$ 3,480	\$ 3,533	\$ 3,587	\$ 3,642	\$ 3,697	\$ 3,753	\$ 3,809	\$ 3,866	\$ 3,923	\$ 3,981	\$ 4,040
Oak Comm College	1.5184	\$ 937	\$ 1,688	\$ 1,714	\$ 1,740	\$ 1,767	\$ 1,794	\$ 1,821	\$ 1,849	\$ 1,877	\$ 1,905	\$ 1,933	\$ 1,962	\$ 1,991	\$ 2,020
Oakland County Parks	0.3500	\$ 216	\$ 389	\$ 395	\$ 401	\$ 407	\$ 414	\$ 420	\$ 426	\$ 433	\$ 439	\$ 446	\$ 452	\$ 459	\$ 466
Huron Clinton Parks	0.2104	\$ 130	\$ 234	\$ 237	\$ 241	\$ 245	\$ 249	\$ 252	\$ 256	\$ 260	\$ 264	\$ 268	\$ 272	\$ 276	\$ 280
General Fund	2.6909	\$ 1,660	\$ 2,991	\$ 3,037	\$ 3,084	\$ 3,132	\$ 3,179	\$ 3,228	\$ 3,277	\$ 3,326	\$ 3,376	\$ 3,426	\$ 3,477	\$ 3,529	\$ 3,580
Local Street	1.0868	\$ 671	\$ 1,208	\$ 1,227	\$ 1,246	\$ 1,265	\$ 1,284	\$ 1,304	\$ 1,323	\$ 1,343	\$ 1,363	\$ 1,384	\$ 1,404	\$ 1,425	\$ 1,446
Fire Fund	2.7000	\$ 1,666	\$ 3,001	\$ 3,047	\$ 3,095	\$ 3,142	\$ 3,190	\$ 3,239	\$ 3,288	\$ 3,337	\$ 3,387	\$ 3,438	\$ 3,489	\$ 3,541	\$ 3,593
Special Police I	1.1552	\$ 713	\$ 1,284	\$ 1,304	\$ 1,324	\$ 1,344	\$ 1,365	\$ 1,386	\$ 1,407	\$ 1,428	\$ 1,449	\$ 1,471	\$ 1,493	\$ 1,515	\$ 1,537
Special Police II	1.1891	\$ 734	\$ 1,322	\$ 1,342	\$ 1,363	\$ 1,384	\$ 1,405	\$ 1,426	\$ 1,448	\$ 1,470	\$ 1,492	\$ 1,514	\$ 1,537	\$ 1,559	\$ 1,582
Pathway	0.1773	\$ 109	\$ 197	\$ 200	\$ 203	\$ 206	\$ 209	\$ 213	\$ 216	\$ 219	\$ 222	\$ 226	\$ 229	\$ 232	\$ 236
RARA Operating	0.1861	\$ 115	\$ 207	\$ 210	\$ 213	\$ 217	\$ 220	\$ 223	\$ 227	\$ 230	\$ 233	\$ 237	\$ 240	\$ 244	\$ 248
OPC Operating	0.3200	\$ 197	\$ 356	\$ 361	\$ 367	\$ 372	\$ 378	\$ 384	\$ 390	\$ 396	\$ 401	\$ 407	\$ 414	\$ 420	\$ 426
OPC Transportation	0.0954	\$ 59	\$ 106	\$ 108	\$ 109	\$ 111	\$ 113	\$ 114	\$ 116	\$ 118	\$ 120	\$ 121	\$ 123	\$ 125	\$ 127
Library Operating	0.7478	\$ 461	\$ 831	\$ 844	\$ 857	\$ 870	\$ 884	\$ 897	\$ 911	\$ 924	\$ 938	\$ 952	\$ 966	\$ 981	\$ 995
Local Total	21.1628	\$ 13,058	\$ 23,520	\$ 23,886	\$ 24,255	\$ 24,628	\$ 25,005	\$ 25,386	\$ 25,770	\$ 26,158	\$ 26,551	\$ 26,947	\$ 27,347	\$ 27,751	\$ 28,159

Non-Capturable Millages	Millage Rate	0	1	2	3	4	5	6	7	8	9	10	11	12	13
Rochester Sch. Debt	3.4800	\$ 2,147	\$ 3,868	\$ 3,928	\$ 3,989	\$ 4,050	\$ 4,112	\$ 4,174	\$ 4,238	\$ 4,301	\$ 4,366	\$ 4,431	\$ 4,497	\$ 4,563	\$ 4,630
Zoo Authority	0.0965	\$ 60	\$ 107	\$ 109	\$ 111	\$ 112	\$ 114	\$ 116	\$ 118	\$ 119	\$ 121	\$ 123	\$ 125	\$ 127	\$ 128
Art Institute	0.1913	\$ 118	\$ 213	\$ 216	\$ 219	\$ 223	\$ 226	\$ 229	\$ 233	\$ 236	\$ 240	\$ 244	\$ 247	\$ 251	\$ 255
Chapter 20 Drain Debt	0.0364	\$ 22	\$ 40	\$ 41	\$ 42	\$ 42	\$ 43	\$ 44	\$ 44	\$ 45	\$ 46	\$ 46	\$ 47	\$ 48	\$ 48
OPC Building Debt	0.1660	\$ 102	\$ 184	\$ 187	\$ 190	\$ 193	\$ 196	\$ 199	\$ 202	\$ 205	\$ 208	\$ 211	\$ 215	\$ 218	\$ 221
Total Non-Capturable Taxes	3.9702	\$ 2,450	\$ 4,412	\$ 4,481	\$ 4,550	\$ 4,620	\$ 4,691	\$ 4,762	\$ 4,835	\$ 4,907	\$ 4,981	\$ 5,055	\$ 5,130	\$ 5,206	\$ 5,283

Total Capturable Millages 45.1628

Total Tax Increment Revenue (TIR) Available for Capture		\$ 50,193	\$ 50,974	\$ 51,762	\$ 52,558	\$ 53,363	\$ 54,175	\$ 54,995	\$ 55,824	\$ 56,661	\$ 57,506	\$ 58,360	\$ 59,222	\$ 60,093
--	--	-----------	-----------	-----------	-----------	-----------	-----------	-----------	-----------	-----------	-----------	-----------	-----------	-----------

Table 2
Tax Increment Revenue Capture Estimates
945 and 975 S. Rochester Road, Rochester Hills,
Oakland County, Michigan

Estimated Taxable Value (TV) Increase Rate: 1% per year

Plan Year	0	14	15	16	17	18	19	20	21	22	23	24	25	TOTAL
Calendar Year	2021	2035	2036	2037	2038	2039	2040							
*Base Taxable Value	\$ 617,020	\$ 617,020	\$ 617,020	\$ 617,020	\$ 617,020	\$ 617,020	\$ 617,020	\$ 617,020	\$ 617,020	\$ 617,020	\$ 617,020	\$ 617,020	\$ 617,020	\$ 617,020
Estimated New TV		\$ 1,967,080	\$ 1,986,751	\$ 2,006,619	\$ 2,026,685	\$ 2,046,952	\$ 2,067,421	\$ 2,088,096	\$ 2,108,976	\$ 2,130,066	\$ 2,151,367	\$ 2,172,881	\$ 2,194,609	
Incremental Difference (New TV - Base TV)		\$ 1,350,060	\$ 1,369,731	\$ 1,389,599	\$ 1,409,665	\$ 1,429,932	\$ 1,450,401	\$ 1,471,076	\$ 1,491,956	\$ 1,513,046	\$ 1,534,347	\$ 1,555,861	\$ 1,577,589	

State Millages	Millage Rate	0	14	15	16	17	18	19	20	21	22	23	24	25	TOTAL
State Education	6.0000	\$ 3,702	\$ 8,100	\$ 8,218	\$ 8,338	\$ 8,458	\$ 8,580	\$ 8,702	\$ 8,826	\$ 8,952	\$ 9,078	\$ 9,206	\$ 9,335	\$ 9,466	\$ 200,340
Rochester Schools Oper.	18.0000	\$ 11,106	\$ 24,301	\$ 24,655	\$ 25,013	\$ 25,374	\$ 25,739	\$ 26,107	\$ 26,479	\$ 26,855	\$ 27,235	\$ 27,618	\$ 28,005	\$ 28,397	\$ 601,021
School Total	24.0000	\$ 14,808	\$ 32,401	\$ 32,874	\$ 33,350	\$ 33,832	\$ 34,318	\$ 34,810	\$ 35,306	\$ 35,807	\$ 36,313	\$ 36,824	\$ 37,341	\$ 37,862	\$ 801,361

Local Millages	Millage Rate	0	14	15	16	17	18	19	20	21	22	23	24	25	TOTAL
Oakland County Operating	4.0200	\$ 2,480	\$ 5,427	\$ 5,506	\$ 5,586	\$ 5,667	\$ 5,748	\$ 5,831	\$ 5,914	\$ 5,998	\$ 6,082	\$ 6,168	\$ 6,255	\$ 6,342	\$ 134,228
Rochester School Sinking	1.4874	\$ 918	\$ 2,008	\$ 2,037	\$ 2,067	\$ 2,097	\$ 2,127	\$ 2,157	\$ 2,188	\$ 2,219	\$ 2,251	\$ 2,282	\$ 2,314	\$ 2,347	\$ 49,664
Oak Int SD-Alloc	0.1918	\$ 118	\$ 259	\$ 263	\$ 267	\$ 270	\$ 274	\$ 278	\$ 282	\$ 286	\$ 290	\$ 294	\$ 298	\$ 303	\$ 6,404
Oak Int SD-Vtd.	3.0362	\$ 1,873	\$ 4,099	\$ 4,159	\$ 4,219	\$ 4,280	\$ 4,342	\$ 4,404	\$ 4,466	\$ 4,530	\$ 4,594	\$ 4,659	\$ 4,724	\$ 4,790	\$ 101,379
Oak Comm College	1.5184	\$ 937	\$ 2,050	\$ 2,080	\$ 2,110	\$ 2,140	\$ 2,171	\$ 2,202	\$ 2,234	\$ 2,265	\$ 2,297	\$ 2,330	\$ 2,362	\$ 2,395	\$ 50,699
Oakland County Parks	0.3500	\$ 216	\$ 473	\$ 479	\$ 486	\$ 493	\$ 500	\$ 508	\$ 515	\$ 522	\$ 530	\$ 537	\$ 545	\$ 552	\$ 11,687
Huron Clinton Parks	0.2104	\$ 130	\$ 284	\$ 288	\$ 292	\$ 297	\$ 301	\$ 305	\$ 310	\$ 314	\$ 318	\$ 323	\$ 327	\$ 332	\$ 7,025
General Fund	2.6909	\$ 1,660	\$ 3,633	\$ 3,686	\$ 3,739	\$ 3,793	\$ 3,848	\$ 3,903	\$ 3,959	\$ 4,015	\$ 4,071	\$ 4,129	\$ 4,187	\$ 4,245	\$ 89,849
Local Street	1.0868	\$ 671	\$ 1,467	\$ 1,489	\$ 1,510	\$ 1,532	\$ 1,554	\$ 1,576	\$ 1,599	\$ 1,621	\$ 1,644	\$ 1,668	\$ 1,691	\$ 1,715	\$ 36,288
Fire Fund	2.7000	\$ 1,666	\$ 3,645	\$ 3,698	\$ 3,752	\$ 3,806	\$ 3,861	\$ 3,916	\$ 3,972	\$ 4,028	\$ 4,085	\$ 4,143	\$ 4,201	\$ 4,259	\$ 90,153
Special Police I	1.1552	\$ 713	\$ 1,560	\$ 1,582	\$ 1,605	\$ 1,628	\$ 1,652	\$ 1,676	\$ 1,699	\$ 1,724	\$ 1,748	\$ 1,772	\$ 1,797	\$ 1,822	\$ 38,572
Special Police II	1.1891	\$ 734	\$ 1,605	\$ 1,629	\$ 1,652	\$ 1,676	\$ 1,700	\$ 1,725	\$ 1,749	\$ 1,774	\$ 1,799	\$ 1,824	\$ 1,850	\$ 1,876	\$ 39,704
Pathway	0.1773	\$ 109	\$ 239	\$ 243	\$ 246	\$ 250	\$ 254	\$ 257	\$ 261	\$ 265	\$ 268	\$ 272	\$ 276	\$ 280	\$ 5,920
RARA Operating	0.1861	\$ 115	\$ 251	\$ 255	\$ 259	\$ 262	\$ 266	\$ 270	\$ 274	\$ 278	\$ 282	\$ 286	\$ 290	\$ 294	\$ 6,214
OPC Operating	0.3200	\$ 197	\$ 432	\$ 438	\$ 445	\$ 451	\$ 458	\$ 464	\$ 471	\$ 477	\$ 484	\$ 491	\$ 498	\$ 505	\$ 10,685
OPC Transportation	0.0954	\$ 59	\$ 129	\$ 131	\$ 133	\$ 134	\$ 136	\$ 138	\$ 140	\$ 142	\$ 144	\$ 146	\$ 148	\$ 151	\$ 3,185
Library Operating	0.7478	\$ 461	\$ 1,010	\$ 1,024	\$ 1,039	\$ 1,054	\$ 1,069	\$ 1,085	\$ 1,100	\$ 1,116	\$ 1,131	\$ 1,147	\$ 1,163	\$ 1,180	\$ 24,969
Local Total	21.1628	\$ 13,058	\$ 28,571	\$ 28,987	\$ 29,408	\$ 29,832	\$ 30,261	\$ 30,695	\$ 31,132	\$ 31,574	\$ 32,020	\$ 32,471	\$ 32,926	\$ 33,386	\$ 706,627

Non-Capturable Millages	Millage Rate	0	14	15	16	17	18	19	20	21	22	23	24	25	TOTAL
Rochester Sch. Debt	3.4800	\$ 2,147	\$ 4,698	\$ 4,767	\$ 4,836	\$ 4,906	\$ 4,976	\$ 5,047	\$ 5,119	\$ 5,192	\$ 5,265	\$ 5,340	\$ 5,414	\$ 5,490	\$ 116,197
Zoo Authority	0.0965	\$ 60	\$ 130	\$ 132	\$ 134	\$ 136	\$ 138	\$ 140	\$ 142	\$ 144	\$ 146	\$ 148	\$ 150	\$ 152	\$ 3,222
Art Institute	0.1913	\$ 118	\$ 258	\$ 262	\$ 266	\$ 270	\$ 274	\$ 277	\$ 281	\$ 285	\$ 289	\$ 294	\$ 298	\$ 302	\$ 6,388
Chapter 20 Drain Debt	0.0364	\$ 22	\$ 49	\$ 50	\$ 51	\$ 51	\$ 52	\$ 53	\$ 54	\$ 54	\$ 55	\$ 56	\$ 57	\$ 57	\$ 1,215
OPC Building Debt	0.1660	\$ 102	\$ 224	\$ 227	\$ 231	\$ 234	\$ 237	\$ 241	\$ 244	\$ 248	\$ 251	\$ 255	\$ 258	\$ 262	\$ 5,543
Total Non-Capturable Taxes	3.9702	\$ 2,450	\$ 5,360	\$ 5,438	\$ 5,517	\$ 5,597	\$ 5,677	\$ 5,758	\$ 5,840	\$ 5,923	\$ 6,007	\$ 6,092	\$ 6,177	\$ 6,263	\$ 132,565

Total Capturable Millages 45.1628

Total Tax Increment Revenue (TIR) Available for Capture \$ 60,973 \$ 61,861 \$ 62,758 \$ 63,664 \$ 64,580 \$ 65,504 \$ 66,438 \$ 67,381 \$ 68,333 \$ 69,295 \$ 70,267

Table 3
Tax Increment Reimbursement Estimates
945 and 975 S. Rochester Road, Rochester Hills,
Oakland County, Michigan

Developer Maximum Reimbursement	Total Proportionality	School & Local Taxes	Local-Only Taxes	Total
State	53.14%	\$ -	\$ -	\$ -
Local	46.86%	\$ -	\$ 508,553	\$ 508,553
TOTAL				
EGLE		\$ -	\$ -	\$ -
MSF		\$ -	\$ -	\$ -

Estimated Total Years of Plan: 25

Estimated Capture	
Administrative Fees	\$ 35,331
State Revolving Fund	\$ -
LBRF	\$ 162,743

	1	2	3	4	5	6	7	8	9	10	11	12	13	14
	2022	2023	2024	2025	2026	2027	2028	2029	2030	2031	2032	2033	2034	2035
Total Local Incremental Revenue	\$ 23,520	\$ 23,886	\$ 24,255	\$ 24,628	\$ 25,005	\$ 25,386	\$ 25,770	\$ 26,158	\$ 26,551	\$ 26,947	\$ 27,347	\$ 27,751	\$ 28,159	\$ 28,571
BRA Administrative Fee (5% of Capture)	\$ 1,176	\$ 1,194	\$ 1,213	\$ 1,231	\$ 1,250	\$ 1,269	\$ 1,289	\$ 1,308	\$ 1,328	\$ 1,347	\$ 1,367	\$ 1,388	\$ 1,408	\$ 1,429
BRA RLF Capture (3% of Capture)	\$ 706	\$ 717	\$ 728	\$ 739	\$ 750	\$ 762	\$ 773	\$ 785	\$ 797	\$ 808	\$ 820	\$ 833	\$ 845	\$ 857
Local TIR Available for Reimbursement	\$ 21,638	\$ 21,975	\$ 22,315	\$ 22,658	\$ 23,005	\$ 23,355	\$ 23,709	\$ 24,066	\$ 24,427	\$ 24,791	\$ 25,159	\$ 25,531	\$ 25,906	\$ 26,285
Total State & Local TIR Available	\$ 21,638	\$ 21,975	\$ 22,315	\$ 22,658	\$ 23,005	\$ 23,355	\$ 23,709	\$ 24,066	\$ 24,427	\$ 24,791	\$ 25,159	\$ 25,531	\$ 25,906	\$ 26,285

DEVELOPER	Beginning Balance	1	2	3	4	5	6	7	8	9	10	11	12	13	14
DEVELOPER Reimbursement Balance	\$ 508,553	\$ 486,914	\$ 464,939	\$ 442,625	\$ 419,967	\$ 396,962	\$ 373,607	\$ 349,898	\$ 325,833	\$ 301,406	\$ 276,615	\$ 251,456	\$ 225,925	\$ 200,019	\$ 173,734

Local Only Costs	\$ 508,553	1	2	3	4	5	6	7	8	9	10	11	12	13	14
Local Tax Reimbursement		\$ 21,638	\$ 21,975	\$ 22,315	\$ 22,658	\$ 23,005	\$ 23,355	\$ 23,709	\$ 24,066	\$ 24,427	\$ 24,791	\$ 25,159	\$ 25,531	\$ 25,906	\$ 26,285
Total Local Only Reimbursement Balance		\$ 486,914	\$ 464,939	\$ 442,625	\$ 419,967	\$ 396,962	\$ 373,607	\$ 349,898	\$ 325,833	\$ 301,406	\$ 276,615	\$ 251,456	\$ 225,925	\$ 200,019	\$ 173,734
Total Annual Developer Reimbursement		\$ 21,638	\$ 21,975	\$ 22,315	\$ 22,658	\$ 23,005	\$ 23,355	\$ 23,709	\$ 24,066	\$ 24,427	\$ 24,791	\$ 25,159	\$ 25,531	\$ 25,906	\$ 26,285

LOCAL BROWNFIELD REVOLVING FUNI

LBRF Deposits *															
State Tax Capture	\$ -	\$ -	\$ -	\$ -	\$ -	\$ -	\$ -	\$ -	\$ -	\$ -	\$ -	\$ -	\$ -	\$ -	\$ -
Local Tax Capture	\$ -	\$ -	\$ -	\$ -	\$ -	\$ -	\$ -	\$ -	\$ -	\$ -	\$ -	\$ -	\$ -	\$ -	\$ -
Total LBRF Capture	\$ -	\$ -	\$ -	\$ -	\$ -	\$ -	\$ -	\$ -	\$ -	\$ -	\$ -	\$ -	\$ -	\$ -	\$ -

* Per City of Rochester Hills Policy, LBRF capture will take place annually consisting of 3% of available tax increment revenue capture and for five years after eligible activities are reimbursed

Table 3
Tax Increment Reimbursement Estimates
945 and 975 S. Rochester Road, Rochester Hills,
Oakland County, Michigan

	15	16	17	18	19	20	21	22	23	24	25	TOTAL
	2036	2037	2038	2039	2040	2041	2042	2043	2044	2045	2046	
Total Local Incremental Revenue	\$ 28,987	\$ 29,408	\$ 29,832	\$ 30,261	\$ 30,695	\$ 31,132	\$ 31,574	\$ 32,020	\$ 32,471	\$ 32,926	\$ 33,386	\$ 706,627
BRA Administrative Fee (5% of Capture)	\$ 1,449	\$ 1,470	\$ 1,492	\$ 1,513	\$ 1,535	\$ 1,557	\$ 1,579	\$ 1,601	\$ 1,624	\$ 1,646	\$ 1,669	\$ 35,331
BRA RLF Capture (3% of Capture)	\$ 870	\$ 882	\$ 895	\$ 908	\$ 921	\$ 934	\$ 947	\$ 961	\$ 974	\$ 988	\$ 1,002	\$ 21,199
Local TIR Available for Reimbursement	\$ 26,668	\$ 27,055	\$ 27,446	\$ 27,840	\$ 28,239	\$ 28,642	\$ 29,048	\$ 29,459	\$ 29,873	\$ 30,292	\$ 30,715	\$ 650,097
Total State & Local TIR Available	\$ 26,668	\$ 27,055	\$ 27,446	\$ 27,840	\$ 28,239	\$ 28,642	\$ 29,048	\$ 29,459	\$ 29,873	\$ 30,292	\$ 30,715	\$ 650,097
DEVELOPER												
<i>DEVELOPER Reimbursement Balance</i>	\$ 147,065	\$ 120,010	\$ 92,564	\$ 64,724	\$ 36,485	\$ 7,843	\$ -	\$ -	\$ -	\$ -	\$ -	\$ -
<hr/>												
Local Only Costs												
Local Tax Reimbursement	\$ 26,668	\$ 27,055	\$ 27,446	\$ 27,840	\$ 28,239	\$ 28,642	\$ 7,843					\$ 508,553
Total Local Only Reimbursement Balance	\$ 147,065	\$ 120,010	\$ 92,564	\$ 64,724	\$ 36,485	\$ 7,843	\$ -					\$ -
Total Annual Developer Reimbursement	\$ 26,668	\$ 27,055	\$ 27,446	\$ 27,840	\$ 28,239	\$ 28,642	\$ 7,843	\$ -	\$ -	\$ -	\$ -	\$ 508,553
LOCAL BROWNFIELD REVOLVING FUNI												
LBRF Deposits *												
State Tax Capture	\$ -	\$ -	\$ -	\$ -	\$ -	\$ -	\$ -	\$ -	\$ -	\$ -	\$ -	\$ -
Local Tax Capture	\$ -	\$ -	\$ -	\$ -	\$ -	\$ -	\$ 21,205	\$ 29,459	\$ 29,873	\$ 30,292	\$ 30,715	\$ 141,544
Total LBRF Capture	\$ -	\$ -	\$ -	\$ -	\$ -	\$ -	\$ 21,205	\$ 29,459	\$ 29,873	\$ 30,292	\$ 30,715	\$ 141,544

* Per City of Rochester Hills Policy, LBRF capture will take place annually consisting of 3% of available tax increment revenue capture and for five years after eligible activities are reimbursed