

**SITE PLAN** 1" = 20' **8**

- 1 A.C. PAVING AND BASE, SEE DETAIL 1/C3.1 AND SOILS REPORT.
- 2 CONSTRUCT 8-INCH CONCRETE PAVEMENT PER DETAIL 2/C3.1 AND SOILS REPORT.
- 3 CONSTRUCT 6" P.C.C. CURB & GUTTER PER DETAIL 4/C3.1
- 4 CONSTRUCT P.C.C. CURB EDGE SIDEWALK PER DETAIL 5/C3.1
- 5 CONSTRUCT P.C.C. SIDEWALK PER DETAIL 6/C3.1
- 6 DEPRESS CURBING AND RAMP SIDEWALK TO MATCH BACK OF CURB GRADE - MAX SLOPE 1:12
- 7 CONSTRUCT SIDEWALK CURB RAMP - MAX SLOPE 1:12. REFER TO GRADING PLAN AND DETAIL 8/C3.1.
- 8 CONSTRUCT P.C.C. DEPRESSED CURB RAMP - MAX. SLOPE 1:12. REFER TO GRADING PLAN AND DETAIL 7/C3.1
- 9 INSTALL GUARD POST BOLLARD PER DETAIL 10/C3.1
- 10 INSTALL BOLLARD AT CURB PER DETAIL 11/C3.1
- 11 CONSTRUCT TRASH ENCLOSURE, ON 8" PCC PAD PER DETAIL 16/C3.1
- 12 INSTALL HAND RAIL ALONG SIDEWALK RAMP. SEE DETAIL 11/C3.1.
- 13 PAINT TRAFFIC ARROWS - WHITE PER DETAIL 1/C3.2
- 14 PAINT 4" WIDE PARKING STRIPES, WHITE REFLECTIVE PAINT
- 15 PAINT MARKED CROSSWALK, 5 FT. MIN. WIDTH AT PEDESTRIAN CROSSING. STRIPES SHALL BE 4" WIDE (MIN.) WITH DIAGONALS @ 4"-0" MAX.
- 16 INSTALL 12" WIDE STOP BAR, WHITE REFLECTIVE THERMOPLASTIC TAPE.
- 17 STRIPE ADA PARKING SPACES PER DETAIL 1/C3.2
- 18 PAINT ADA SYMBOL - WHITE ON BLUE BACKGROUND (1-REG. SPACE, 1-VAN SPACE).
- 19 ACCESSIBLE PARKING SIGN, PER DETAIL 3/C3.2 (1-REG. SPACE, 1-VAN SPACE)
- 20 ACCESSIBLE "SWING-SIDE" MANEUVERING SPACE AT ALL EXTERIOR DOORS. 2% MAX. SIDEWALK SLOPE, 2' TO STRIKE SIDE OF DOOR, 5' OUT FROM DOOR.
- 21 DETECTIBLE WARNING STRIPS PER ANSI A117.1/ADA GUIDELINES. WARNINGS SHALL EXTEND THE FULL WIDTH OF THE RAMP.
- 22 DOUBLE FACED, ILLUMINATED, DIRECTIONAL SIGN (SIGN FACE AS NOTED), BY SIGN SUPPLIER. FOUNDATION BY SIGN COMPANY AND ROUGH ELECTRICAL BY G.C. UNDER SEPARATE PERMIT. SEE DETAIL 12/C3.2.
- 23 TACO BELL MENU BOARD, SENSOR LOOP & ORDER CONFIRMATION BOARD BY SIGN SUPPLIER. FOUNDATION AND ROUGH ELECTRICAL BY G.C. (4.0 AMPS). REFER TO DETAIL 14/C3.2 AND 16/E6.0.
- 24 INSTALL TIMER LOOP AT PICK-UP WINDOW PER DETAIL 16/E6.0.
- 25 TACO BELL SOFFIT CLEARANCE SIGN SUPPLIED BY OWNER, INSTALLED BY G.C. REFER TO DETAIL 2/C3.2.
- 26 INSTALL TIMER LOOP AT ORDER CONFIRMATION BOARD PER DETAIL 14/C3.1 AND 16/E6.0.
- 27 400 WATT (208) VOLT YARD LIGHT W/FULL CUT-OFF LENSES. LIGHT FIXTURES SUPPLIED BY OWNER, INSTALLED BY G.C. MAX. OVERALL STANDARD HEIGHT = 20'-0". SEE DETAIL 7C3.2 AND 8/C3.2.
- 28 INSTALL 190 L.F. OF 6" SCH 40 PVC SANITARY SEWER LEAD W/ CLEANOUTS @ 100' O.C. SEE UTILITY PLAN FOR DETAILS.
- 29 INSTALL 1,000-GALLON GREASE INTERCEPTOR PER DETAIL 4/C6.1. SEE UTILITY PLAN FOR LOCATIONS OF SEWER LATERALS, AND CLEANOUTS.
- 30 CLEANOUT TO GRADE FOR BUILDING SEWERS. SEE PLUMBING PLANS AND DETAIL 1/C5.1.
- 31 CONNECT TO EXISTING SANITARY SEWER. SEE UTILITY PLAN.
- 32 INSTALL 110 L.F. 2" SDR 9 POLYETHYLENE WATER SERVICE WITH TRACER WIRE. INSTALL NEW CURB STOP AND BOX PER CITY OF ROCHESTER HILLS SPECIFICATIONS. SEE UTILITY PLAN.
- 33 INSTALL WATER POINT OF ENTRY. SEE PLUMBING & CIVIL PLANS. (BRING UP IN BUILDING). PROVIDE SHUT OFF VALVE AT POINT OF ENTRY.
- 34 ELECTRICAL MAIN SWITCHBOARD. SEE ELECTRICAL DRAWINGS.
- 35 GAS METER
- 36 COORDINATE ALL UTILITY WORK WITH UTILITY COMPANIES.
- 37 CONSTRUCT STORM INLET PER CITY OF ROCHESTER HILLS STORM SYSTEM STANDARD DETAILS (AFTER INSTALLATION PLACE FILTER FABRIC OVER INLET AND LINE WITH STONE).
- 38 CONSTRUCT STANDARD CATCH BASIN PER CITY OF ROCHESTER HILLS STORM SYSTEM STANDARD DETAILS. (AFTER INSTALLATION PLACE FILTER FABRIC OVER INLET AND LINE WITH STONE).
- 39 CONSTRUCT STORM SEWER MANHOLE PER CITY OF ROCHESTER HILLS STORM SYSTEM STANDARD DETAILS.
- 40 INSTALL AQUA-SWIRL AS-3 WATER QUALITY UNIT. REFER TO UTILITY PLAN AND DETAIL 8/C6.1.
- 41 CONSTRUCT SEGMENTAL RETAINING WALL. SEE DETAIL 6/C6.1.
- 42 INSTALL 3' ORNAMENTAL FENCE. SEE DETAIL 12/C3.1.
- 43 LANDSCAPE AREA. REFER TO LANDSCAPE DRAWINGS.

**SIGNAGE NOTES:**  
 1. ALL SIGNAGE SHALL BE PERMITTED UNDER SEPARATE SIGN PERMIT BY SIGN VENDOR.  
 A - 'THANK YOU'  
 B - 'EXIT ONLY'

**KEYED SITE NOTES** **3**

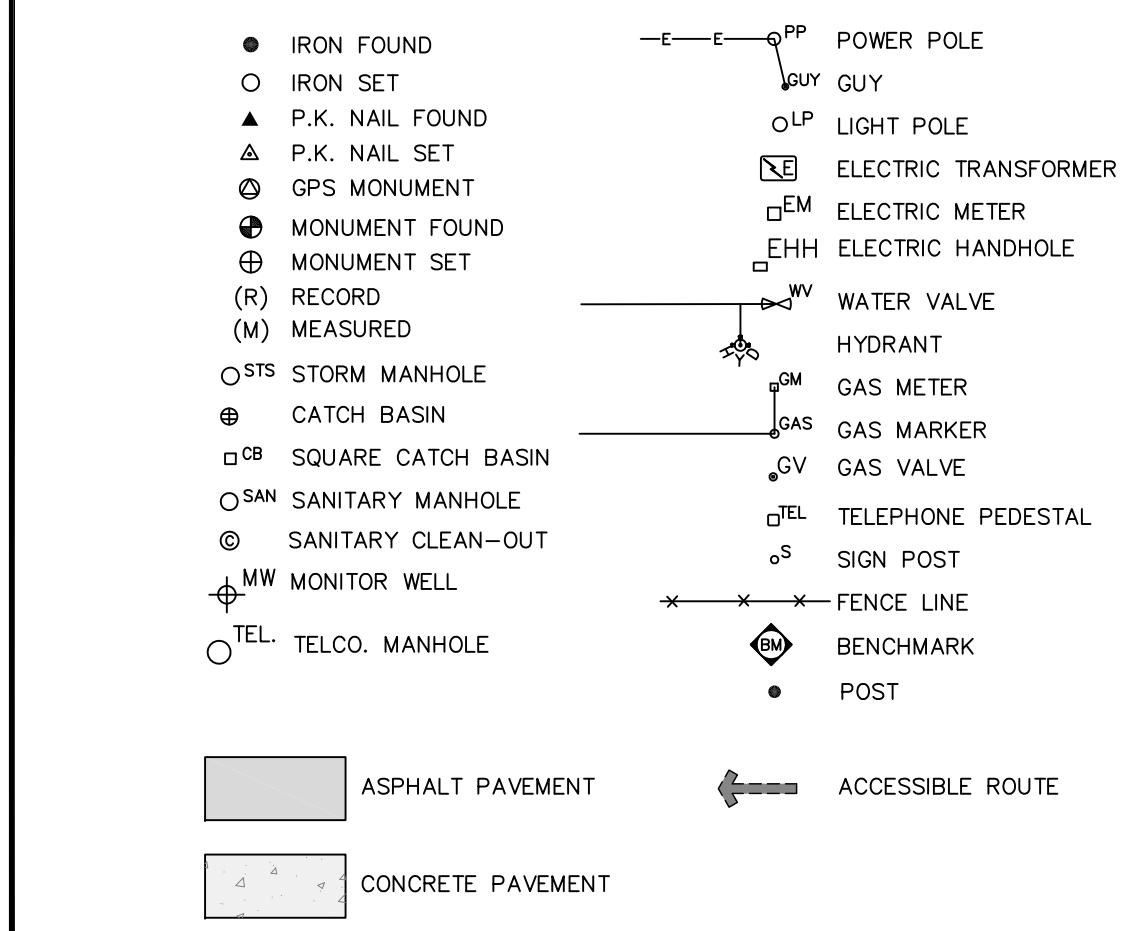

**LEGEND** **4**

**LANDTECH**  
 Professional Surveying & Engineering  
 P.O. BOX 193  
 1275 MCGREGOR WAY  
 GRAWIN, MI 49637  
 PH: 231.943.0050  
 FAX: 231.943.0051  
 TOLL FREE: 877.520.LAND  
 www.landtechps.com

**WT DEVELOPMENT CORPORATION**  
 WT Development Corporation  
 10223 E. Cherry Bend Rd., Ste. A  
 Traverse City, Michigan, 49684  
 Contact: Bill Becker, President  
 Phone: (231) 922-9250  
 Fax: (231) 922-9257

**PROJECT CONSULTANT**

ISSUE DATE:	XX.XX.XX
△	
△	
△	
△	
△	
△	
△	
△	
△	
△	
△	

CONTRACT DATE:	XX.XX.XX
BUILDING TYPE:	T50
PLAN VERSION:	JULY 2011
SITE NUMBER:	307630
ENTITY NUMBER:	396088

**TACO BELL**  
 WALTON ROAD  
 ROCHESTER HILLS, MI



**T50**  
**SITE PLAN**

**C3.0**  
 PLOT DATE: 01.30.12