







# Wordmark Fascia - LED



|                      |                     |
|----------------------|---------------------|
| <b>Illumination:</b> | LED                 |
| <b>Electrical:</b>   | 2.6 Amps 12V 60HZ   |
| <b>Ballast:</b>      | 2- AMPEROR ANP90-30 |
| <b>Ship Weight:</b>  | 140 lbs.            |

41.25 sqft.

# 42" Illuminated Building Arch

(Modified 48")

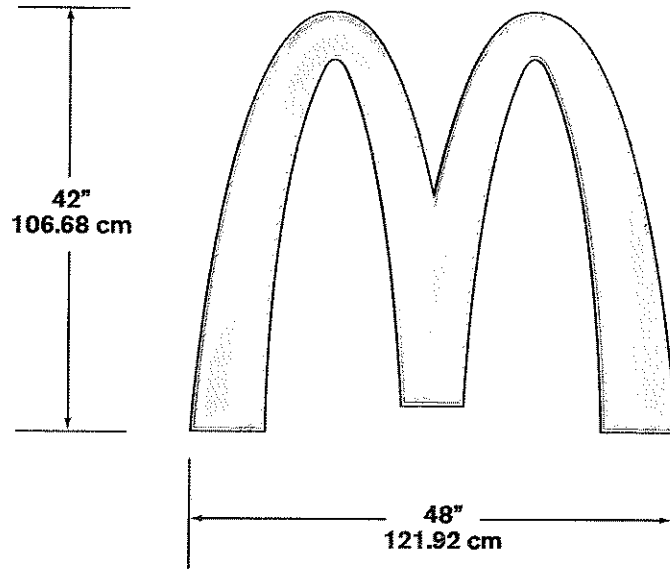

|                      |           |
|----------------------|-----------|
| <b>Illumination:</b> | Neon      |
| <b>Electrical:</b>   | 1.25 Amps |
| <b>Ballast:</b>      | 1-12/30   |
| <b>Ship Weight:</b>  | 110 lbs.  |

**LED version available soon**

*129 sqft.*