

AUTO RITE SALES

1927 E. AUBURN RD., ROCHESTER HILLS, MI 48307

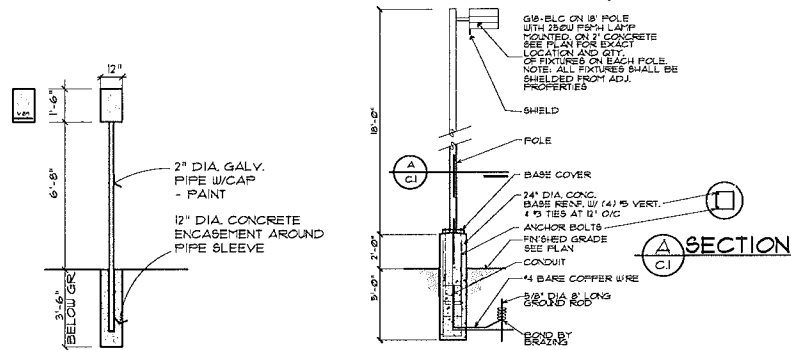

B.F. PARKING SIGN
NT6

TYP. LIGHT POLE
NT6

SITE/BLDG DATA:

ZONING: C1 COMMERCIAL
 USE GROUP: B/S1 MIXED USE NON-SEPARATED
 SIZE: 12,832 SF. = 0.29 ACRE
 LOT FRONTAGE: 93.18' (E. AUBURN RD.)
 LOT DEPTH: 140' (HESSSEL)
 HOURS OF OPERATION: 9 AM TO 6 PM
 HOURS OF FUNCTION FOR ALL EXTERIOR LIGHTING: DUSK TO 11 PM
 BUSINESS SIGN LOCATION: ON EAST SIDE OF BUILDING
 CONSTRUCTION TYPE (SECT. 602): TYPE 2B
 BUILDING AREA: 1151 SF.
 PARKING REQUIRED: 1151/300 = 6 CARS
 PARKING PROVIDED: 6 CARS

FIRE SUPPRESSION: NO

TRASH TO BE CONTAINED WITHIN THE BUILDING AND PICKED UP PERIODICALLY.

OUTDOOR STORAGE NOT ALLOWED.

LOADING SPACE NOT REQUIRED FOR THIS FACILITY.

BUILDING CODES:

2012 MICHIGAN BUILDING CODE
 2012 MICHIGAN PLUMBING CODE
 2012 MICHIGAN MECHANICAL CODE
 2011 NATIONAL ELECTRICAL CODE (WITH MICHIGAN AMENDMENTS)
 MICHIGAN BARRIER FREE - ICC/ANSI A117.1-2003
 2003 MICHIGAN UNIFORM ENERGY CODE PART 10A
 ANSI/ASHRAE/IESNA STANDARD 90.1 - 2001
 2012 INTERNATIONAL FIRE CODE

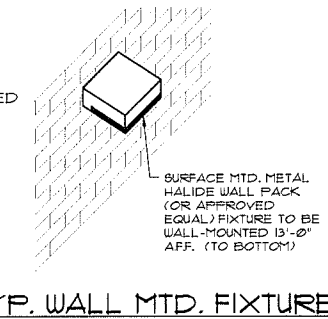

TYP. WALL MTD. FIXTURE
NT6

INDEX OF DRAWINGS	
C1	SITE PLAN, FLOOR PLANS, ELEVATIONS, BUILDING DATA AND DETAILS
1	STORM SEWER/UTILITY PLAN
LS1	LANDSCAPE PLAN
ET	PHOTOMETRIC PLAN

LEGAL DESCRIPTION:

T3N, R11E, SEC 25 SUPERVISOR'S PLAT BROOKLANDS PARK NO. 3 LOTS 1321

SIGNS:
 ALL SIGNS MUST MEET SECTION 138-6.304 AND CHAPTER 134 OF THE CITY CODE OF ORDINANCES AND BE APPROVED UNDER A SEPARATE PERMIT ISSUED BY THE BUILDING DEPARTMENT.

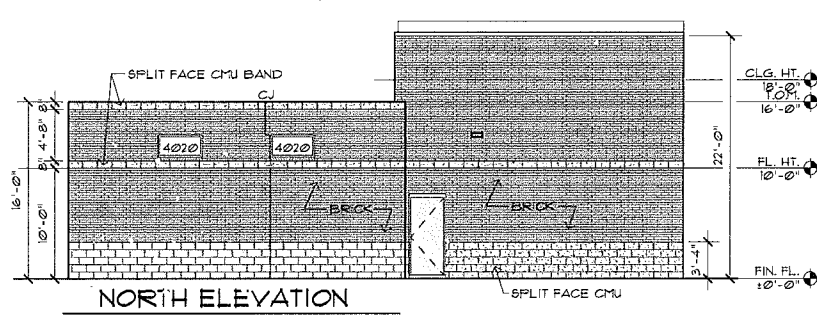

NORTH ELEVATION
SCALE: 1/8" = 1'-0"

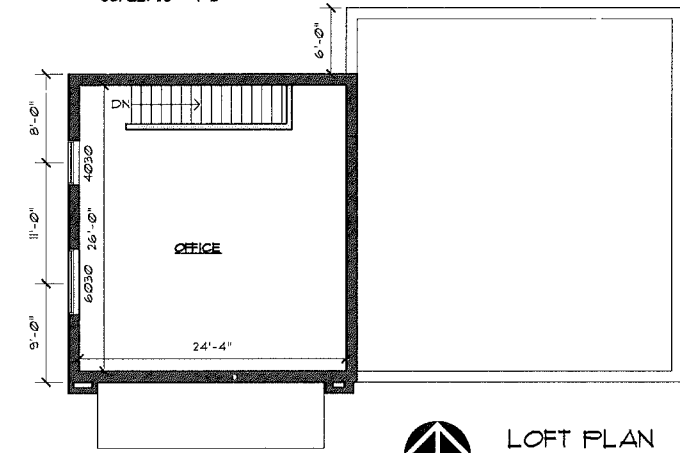

LOFT PLAN
SCALE: 1/8" = 1'-0"

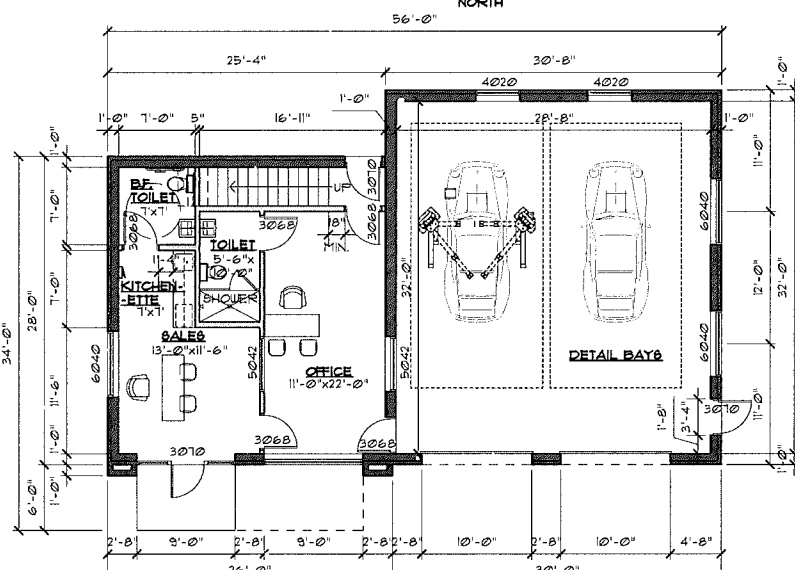

FLOOR PLAN
SCALE: 1/8" = 1'-0"

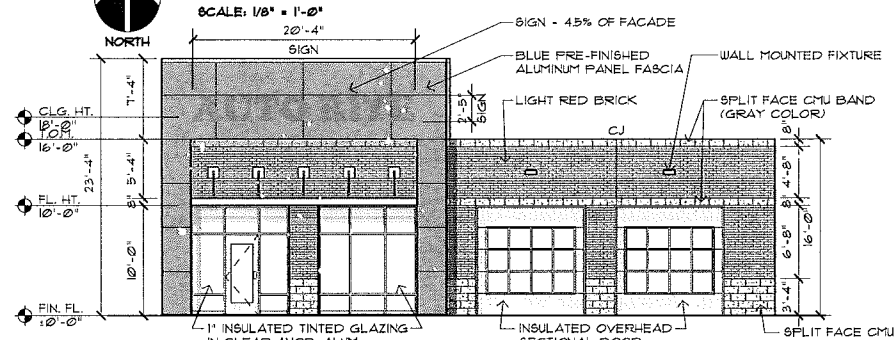

WEST ELEVATION
SCALE: 1/8" = 1'-0"

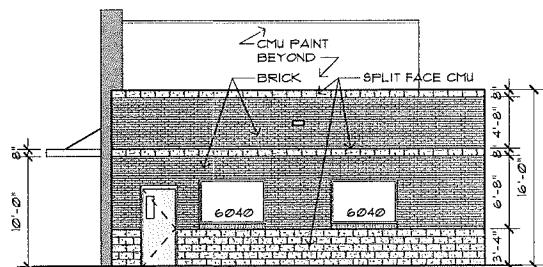

EAST ELEVATION (HESSSEL)
SCALE: 1/8" = 1'-0"

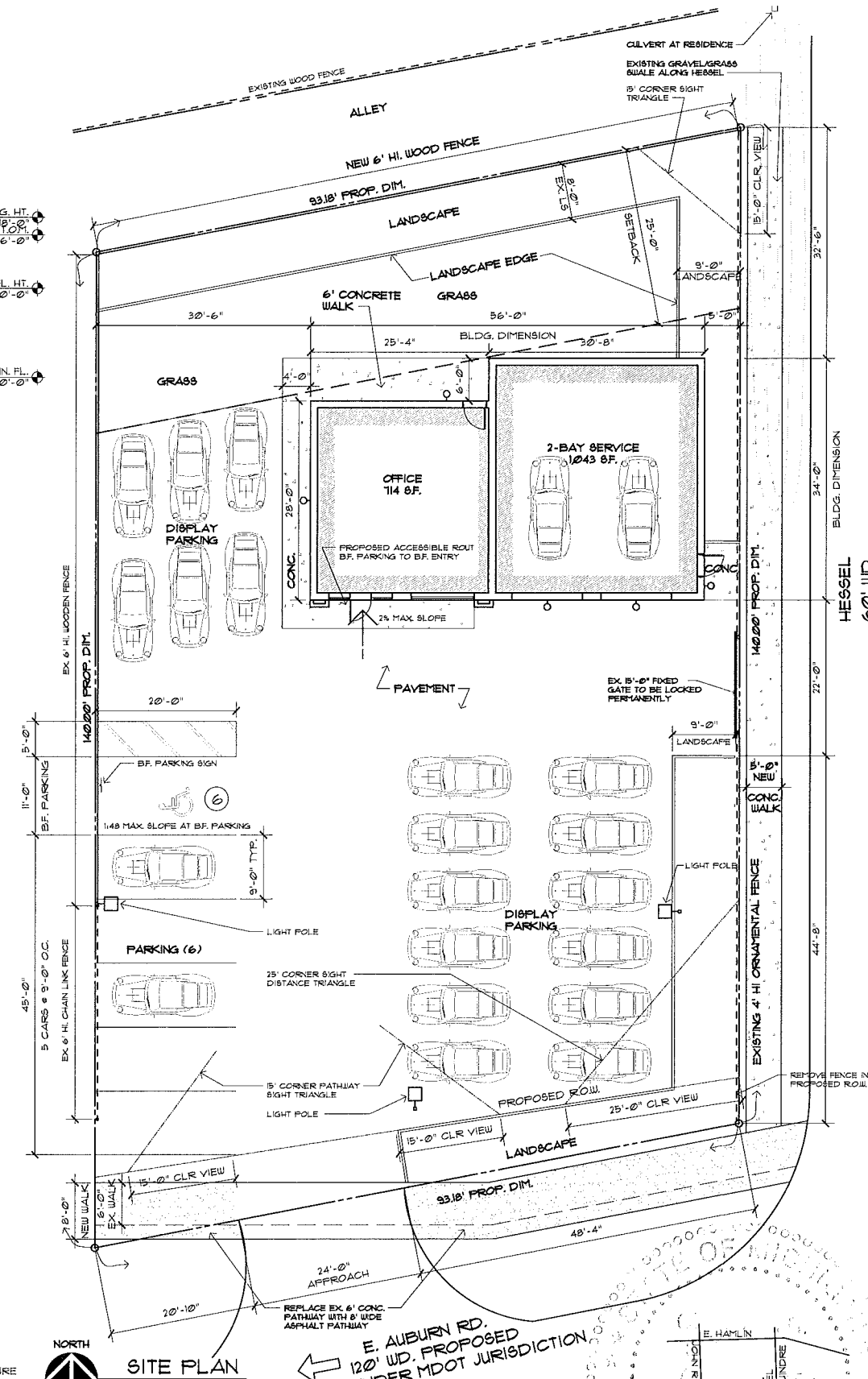

SITE PLAN
SCALE: 1" = 10'-0"

- FIRE DEPARTMENT NOTES:**
- A KNOX KEY SYSTEM SHALL BE INSTALLED, IN A LOCATION APPROVED BY THE FIRE CODE OFFICIAL. ORDERING INFORMATION IS AVAILABLE FROM THE KNOX COMPANY AT KNOXBOX.COM.
 - PROVIDE 1 KNOX BOX ON BUILDING ADJACENT TO MAIN ENTRANCE DOOR.
 - FIRE LANES SHALL BE DESIGNATED BY THE FIRE CODE OFFICIAL, AND SHALL BE CONSPICUOUSLY POSTED ON BOTH SIDES OF THE FIRE LANE, WITH FIRE LANE SIGNS SPACED NOT MORE THAN 100 FEET APART. FIRE LANE SIGNS SHALL READ 'NO STOPPING, STANDING, PARKING, FIRE LANE', AND SHALL CONFORM TO THE MICHIGAN MANUAL OF UNIFORM TRAFFIC CONTROL DEVICES.
 - CONSTRUCTION SITE SHALL BE SAFEGUARDED IN ACCORDANCE WITH IFC 2006 CHAPTER 14.
 - OPEN BURNING IS NOT PERMITTED INCLUDING THE BURNING OF TRASH, DEBRIS, OR LAND CLEARING MATERIALS. OPEN BURNING FOR WARMING OF SAND AND/OR WATER FOR THE PREPARATION OF MORTAR SHALL BE WITHIN THE CITY OF ROCHESTER HILLS BURN PERMIT GUIDELINES.

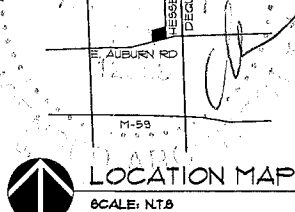

LOCATION MAP
SCALE: N.T.S.

OWNER:
 SYED AHMED
 (248) 875-3134

COPYRIGHT © 2015
 THIS DOCUMENT AND SUBJECT MATTER CONTAINED THEREIN IS THE PROPERTY OF CHESTER STEPIEN ASSOCIATES. NO PART OF THIS DOCUMENT IS TO BE REPRODUCED OR TRANSMITTED IN ANY FORM OR BY ANY MEANS WITHOUT THE WRITTEN PERMISSION OF CHESTER STEPIEN ASSOC.

PROJECT
AUTO RITE LLC
 1927 E. AUBURN RD.
 ROCHESTER HILLS, MI 48307

SUBJECT
**PROPOSED SITE PLAN,
 FLOOR PLANS, ELEVATIONS,
 BLDG. DATA AND DETAILS**

ARCHITECTS
CHESTER STEPIEN ASSOCIATES • AIA
 28895 GREENFIELD ROAD SOUTHFIELD, MICHIGAN 48076
 (248) 357-2145 FAX (248) 369-2836

ISSUED:
 PLANNING: 11/10/2015
 REVISION: 12/21/2015

DRAWN: VS
 CHECKED: C.R.S.
 APPROVED: C.R.S.
 ADS
 CONSTR

DO NOT SCALE PRINTS - USE DIMENSIONS ONLY

JOB NO.
24001

SHEET
C.1

SOIL BORING DATA

DEPTH	DESCRIPTION
• SB#1	2" FROZEN DARK BROWN SANDY TOPSOIL W/TRACE OF VEGETATION, FILL
8"	FROZEN BROWN AND GRAY FINE SAND W/ TRACE OF GRAVEL AND OCCASIONAL STONES, FILL
3'4"	MEDIUM COMPACT MOIST BROWN FINE SAND W/TRACE OF GRAVEL, LITTLE PEBBLES, OCCASIONAL STONES AND POSSIBLE ORGANIC STREAKS, FILL
6'0"	SLIGHTLY COMPACT WET BROWN FINE TO MEDIUM SAND W/TRACES OF GRAVEL AND SILT
8'6"	MEDIUM COMPACT WET BROWN FINE SAND W/TRACE OF GRAVEL
11'6"	EXTREMELY COMPACT WET BROWN FINE SAND W/TRACE OF GRAVEL
• SB#2	5" FROZEN BLACK ASPHALT MILLINGS
10"	FROZEN GRAY SAND & GRAVEL, AGGREGATE FILL
2'4"	VERY COMPACT MOIST BROWN FINE SAND W/TRACE OF GRAVEL, CINDERS AND DARK BROWN TOPSOIL STREAKS, FILL
3'9"	COMPACT MOIST BROWN FINE SAND W/TRACE OF GRAVEL, FILL
5'8"	COMPACT VERY MOIST BROWN FINE SAND W/TRACE OF GRAVEL, FILL
6'0"	COMPACT VERY MOIST DARK BROWN TO BLACK SANDY TOPSOIL
6'6"	COMPACT MOIST BROWN FINE SAND W/TRACE OF GRAVEL AND TOPSOIL STREAKS (BAG SAMPLE)
12'0"	COMPACT WET BROWN FINE TO MEDIUM SAND W/TRACES OF GRAVEL AND SILT
15'0"	EXTREMELY COMPACT WET BROWN FINE TO MEDIUM SAND W/TRACE OF GRAVEL

NOTES:

- INSTALLED 1" DIAMETER PVC PIEZOMETER IN BORING WITH SCREEN BOTTOM AT 14' AND 3' STICK-UP.
- WATER LEVEL IN PIEZOMETER AT COMPLETION AT 7.96' BELOW GROUND SURFACE.

PRELIMINARY

QUANTITIES THIS SHEET

ITEM	UNIT	AMOUNT
12" RCP C76 CLIV STORM SEWER	LF	26
STORM CATCH BASIN, 4' DIA	EA	2
STORM MANHOLE, 4' DIA	EA	1
CONTECH CDS-4, 4' DIA	EA	1
CONTECH CMP DETENTION SYSTEM (PER DETAIL THIS SHEET)	LS	1
6" SCH40 SANITARY SEWER LEAD	LF	45
1" TYPE K COPPER WATER SERVICE	LF	53
ON-SITE PAVEMENT	SY	800

DYODS™
Design Your Own Detention System

CONTECH
CONCRETE CDS SYSTEMS

For design information, visit our website at www.contech-cds.com or call 1-800-451-8111.

Project Summary:

Date:	10/21/15
Project Name:	Auto Rite LLC
City/County:	Rochester Hills, MI
State:	MI
Designed By:	CONTECH
Company:	CONTECH
Telephone:	1-800-451-8111

Design Parameters:

Storage Volume Required (cu ft):	16,500
Length (ft):	100.00
Height (ft):	1.10
Number of Inlets:	2
Number of Outlets:	1
Number of Manholes:	1
Number of Stormwater Inlets:	2
Number of Stormwater Outlets:	1
Number of Manholes:	1
Number of Stormwater Inlets:	2
Number of Stormwater Outlets:	1
Number of Manholes:	1

System Details:

Flow Rate:	1650 cfs
Flow Velocity:	2.00 ft/s
Flow Depth:	1.10 ft
Flow Width:	100.00 ft
Flow Area:	11000.00 sq ft
Flow Capacity:	1650 cfs
Flow Efficiency:	100%

System Layout

System Details

System Details

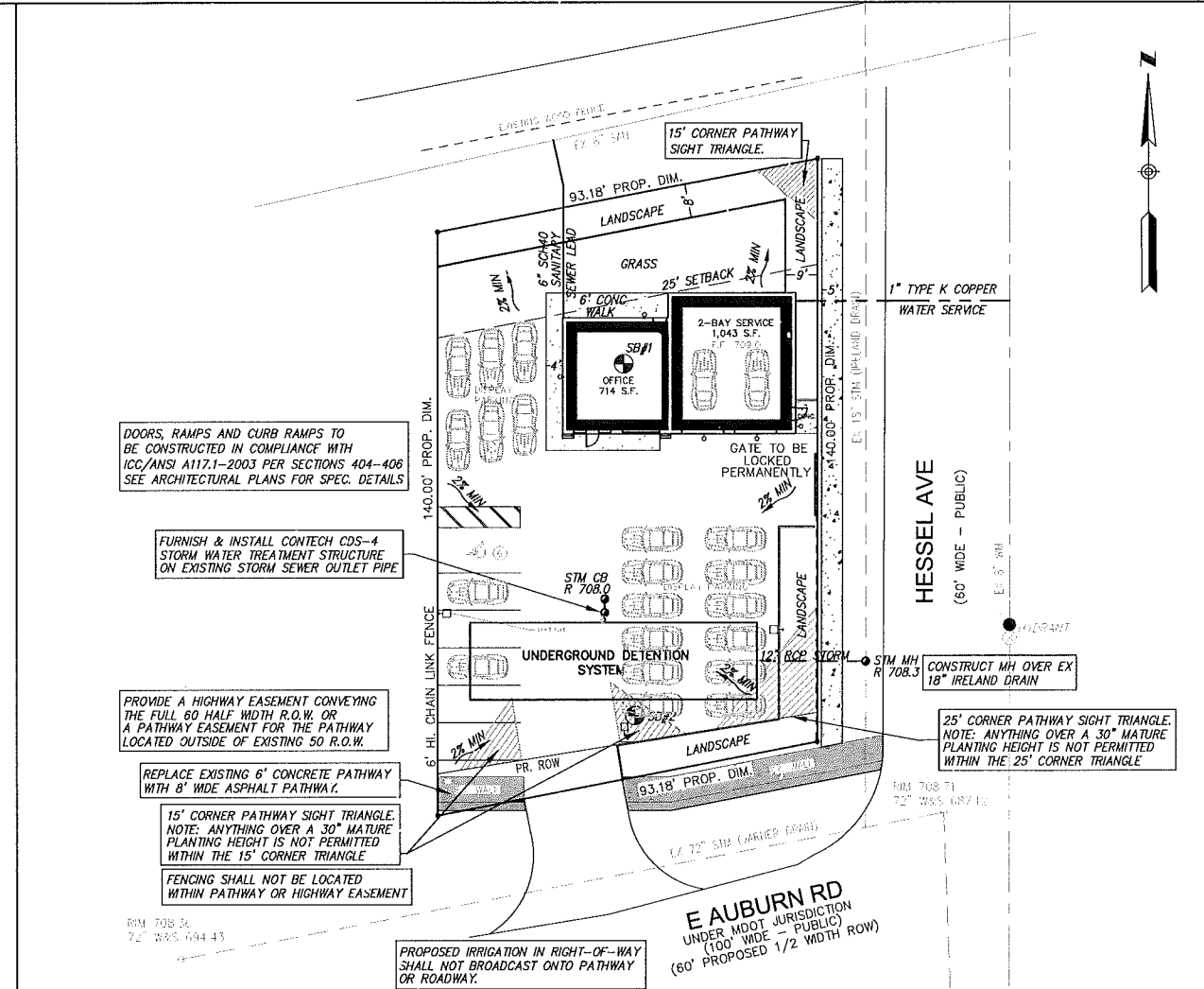

SANITARY SEWER BASIS OF DESIGN

UNIT FACTOR: 0.3 UNITS PER 1000 SQ. FT.
2,500 SQ. FT. X 0.3 = 0.75 UNITS

INITIAL FLOW: 3 PEOPLE/ UNIT
TOTAL POPULATION = 2.5 PEOPLE = 3.0 PEOPLE
AVE. FLOW = 100 GAL/CAPITA/DAY X 3.0 PEOPLE = 0.0005 CFS
86,400 SEC/DAY X 7.48 GAL/C.F. = 0.0005 CFS

PEAK FLOW = [(18 + √.003) / (4 + √.003) X 0.0005] = 0.002 CFS

FUTURE POPULATION: INITIAL POPULATION = FUTURE POPULATION = 3.0 PEOPLE

ULTIMATE FLOW: INITIAL FLOW = ULTIMATE FLOW

STORM SEWER CALCULATIONS

STORM SEWER OUTLET: IRELAND DRAIN (18")

PER OC-WRC IRELAND DRAIN STORM CALCULATIONS
DESIGN FLOW TO MH11 OF VARNER DRAIN

C = 0.3 A = 8 AC T_c = 80.31 MIN
Q_s = 2.40 CFS

AUTO RITE LLC SITE

AREA = 0.29 AC
C = 70% 0.95 (FUTURE PAVEMENT/BUILDING)
30% 0.15 (GREENBELT)
= 0.71

T = 15 MIN, I_s = 215/T + 25 = 1.11
Q = 0.98 CFS
Q_s = 0.2 CFS/AC
Q_o = 0.06 CFS
Q_o = Q_s / A x C = 0.28 CFS
CONTECH CDS-4 TREATMENT FLOW CAPACITY = 0.70 CFS

V_t VOLUME OF STORAGE REQUIRED FOR 100 YR STORM

T₁₀₀ = -25 + √(10,312.5/Q_o) = 166.34 MIN
V_{s100} = (16,500 x T) / (T + 25) - 40 x Q x T = 12,469.90 FT³
V_t = V_{s100} / (A x C) = 2,567.55 FT³
VOLUME PROVIDED 2,627 FT³

EXISTING WATER TABLE ELEVATION IS APPROXIMATELY 700. THE BOTTOM OF THE ON-SITE STORAGE IS 702.

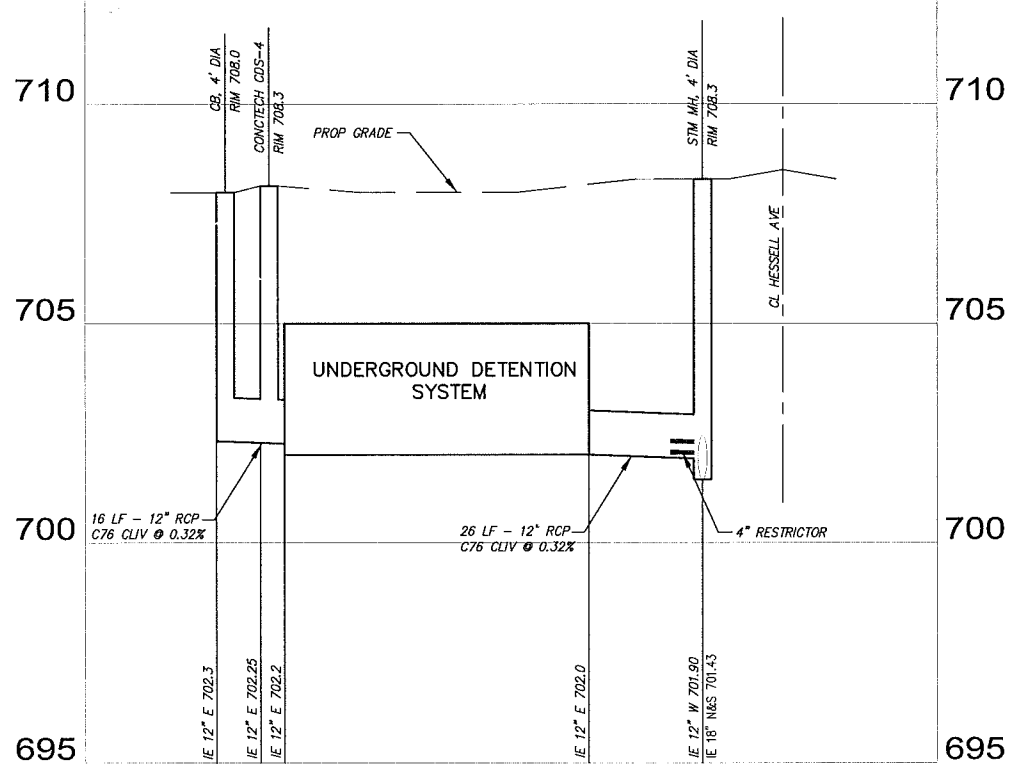

CITY OF ROCHESTER HILLS AUTO RITE LLC STORM SEWER/UTILITY PLAN

NO.	DATE	SUBMITTAL	NO.	DATE	REVISION
1	6/19/14	OWNER	1	5/15/15	PER R.H. REVIEW (4/22/15)
2	3/17/15	OWNER	2	5/20/15	PER STEPIEN REVIEW (5/16/15)
3	11/10/15	PLANNING	3	5/21/15	PER STEPIEN REVIEW (5/21/15)
4	12/21/15	PLANNING	4	6/01/15	PER STEPIEN REVIEW (5/29/15)
			5	9/15/15	PER CITY REVIEW (8/27/15)
			6	10/6/15	PER CITY REVIEW (8/28/15)
			7	11/19/15	PER CITY REVIEW (10/28/15)
			8	12/17/15	PER STEPIEN/CITY MTC

PROJECT NO.: RH14-026
DRAWING NO.: RH14026D1
SCALE: 1"=20'
DRAWN BY: L. RODRIGUEZ
DATE: 6/19/14
CHECKED BY: M. O'CONNOR
DATE: 6/19/14
SECTION: 25 TOWN 3 NORTH RANGE 11 EAST
CITY/TOWN: ROCHESTER HILLS OAKLAND COUNTY, MI

SHEET NO. 1

CALL 811 MISS DIG 12 HOURS (3 WORKING DAYS) BEFORE YOU DIG 1-800-482-1171
CALL.811.COM (TOLL FREE)

CHIPPEWA CONSULTING
ENGINEERING EXCELLENCE

8140 PACTON
SHELBY TOWNSHIP, MI 48317
PH: (586)737-7993
FAX: (586)737-7994
www.chippewaconsultingllc.com

MINA
Certified Minority Owned
and Woman Owned Business Enterprise

general landscape notes:

- LANDSCAPE CONTRACTOR SHALL VISIT THE SITE, INSPECT EXISTING CONDITIONS, REVIEW PROPOSED PLANTINGS AND RELATED WORK. CONTACT THE OWNER AND/OR LANDSCAPE ARCHITECT WITH ANY CONCERNS OR DISCREPANCY BETWEEN THE PLAN, PLANT MATERIAL LIST, AND/OR SITE CONDITIONS.
- NUMERICAL VALUE ON THE LANDSCAPE QUANTITIES SPECIFIED ON THE PLAN TAKE PRECEDENCE OVER GRAPHIC REPRESENTATION. VERIFY ANY CONCERN/DISCREPANCY WITH LANDSCAPE ARCHITECT.
- ALL CONSTRUCTION AND PLANT MATERIAL LOCATION TO BE ADJUSTED ON SITE IF NECESSARY.
- ALL SUBSTITUTIONS OR DEVIATIONS FROM THE LANDSCAPE PLAN MUST BE APPROVED BY ROCHESTER HILLS AND LANDSCAPE ARCHITECT.
- ALL LARGE TREES AND EVERGREENS TO BE STAKED, GUYED AND WRAPPED AS DETAIL SHOWN ON PLAN.
- PLANT BEDS TO BE DRESSED WITH MIN. 3" OF FINELY DOUBLE SHREDDED HARDBARK MULCH.
- DIG SHRUB PITS 1' LARGER THAN SHRUB ROOT BALLS AND TREE PITS 2' LARGER THAN ROOT BALL. BACK FILL WITH ONE PART TOP SOIL AND ONE PART SOIL FROM EXCAVATED PLANTING HOLE.
- REMOVE ALL TWINE, WIRE AND BURLAP FROM TREE AND SHRUB EARTH BALLS, AND FROM TREE TRUNKS.
- NATURAL COLOR, FINELY SHREDDED HARDWOOD BARK MULCH REQUIRED FOR ALL PLANTINGS. 4" THICK BARK MULCH FOR TREES IN 4" DIA. CIRCLE WITH 3" PULLED AWAY FROM TRUNK. 3" THICK BARK MULCH FOR SHRUBS AND 2" THICK BARK MULCH FOR PERENNIALS.
- PLANT MATERIAL QUALITY & INSTALLATION SHALL BE IN ACCORDANCE WITH THE CURRENT AMERICAN ASSOCIATION OF NURSERMEN LANDSCAPE STANDARDS.
- PROVIDE PEAT BOD FOR ALL NEW AND DISTURBED LAWN AREAS UNLESS NOTED OTHERWISE.
- ALL PLANTING AREAS TO BE PREPARED WITH APPROPRIATE SOIL MIXTURES AND FERTILIZER BEFORE PLANT INSTALLATION.
- PLANT TREES AND SHRUBS GENERALLY NO CLOSER THAN THE FOLLOWING DISTANCES FROM SIDEWALKS, CURBS AND PARKING STALLS:
 - SHADE TREES _____ 5 FT.
 - ORNAMENTAL AND EVERGREEN TREES (CRAB, PINE, SPRUCE, ETC.) _____ 10 FT.
 - SHRUBS THAT ARE LESS THAN 1 FOOT TALL AND WIDE AT MATURITY _____ 2 FT.
- NO TREES OR EVERGREENS TO BE INSTALLED OVER ANY PROPOSED OR EXISTING UTILITY LINES AS SHOWN ON THE COVERED LANDSCAPE PLAN. SEE ENGINEERING PLANS FOR EXACT LOCATION AND DETAILS.
- PRIOR TO BEGINNING OF CONSTRUCTION ON ANY WORK, CONTRACTORS SHALL VERIFY LOCATIONS OF ALL ON-SITE UTILITIES (GAS, ELECTRIC, TELEPHONE, CABLE) TO BE LOCATED BY CONTACTING 1-888-218-1889-489-TIL. ANY DAMAGE OR INTERRUPTION OF SERVICES SHALL BE THE RESPONSIBILITY OF THE CONTRACTOR. COORDINATE ALL RELATED WORK ACTIVITIES WITH OTHER TRADES AND REPORT ANY UNACCEPTABLE JOB CONDITIONS TO OWNER PRIOR TO COMMENCEMENT.
- ALL LAWN AREAS AND LANDSCAPE BEDS TO BE FULLY IRRIGATED WITH AN AUTOMATIC UNDERGROUND SYSTEMS. IRRIGATION SYSTEM TO HAVE SEPARATE ZONES FOR LAWN AREAS, PARKING ISLANDS, AND SHRUB BEDS WITH DIFFERENT CONTROL MOISTURE LEVEL ADJUSTMENT PER ZONE AS REQUIRED.

WATERING WILL ONLY OCCUR BETWEEN THE HOURS OF 12:00 AM AND 9:00 AM.
- UNLESS NOTED OTHERWISE, LANDSCAPE BEDS ADJACENT TO LAWN TO RECEIVE EDGING. EDGING SHALL BE 4" x 1/8" METAL (FINISH BLACK OR GREEN) OR APPROVED EQUAL, AND TO BE INSTALLED WITH HORIZONTAL METAL STAKES AT 3' O.C. OR PER MANUFACTURER'S SPECIFICATION.
- ALL LANDSCAPE BEDS ADJACENT AND NEXT TO BUILDING SHALL BE EXCAVATED OF ALL BUILDING MATERIALS AND FLOOR SOILS A MIN. OF 12" DEPTH. BACK FILL WITH GOOD, MEDIUM TEXTURED PLANTING SOILS. ADD A MIN. 2" OF TOPSOIL OVERFILL TO FINISH GRADE. PROVIDE POSITIVE DRAINAGE.
- WATERING OF ALL PLANTS AND TREES TO BE PROVIDED IMMEDIATELY AND MULCHING WITHIN 24 HOURS AFTER INSTALLATION.
- ALL TREE PITS TO BE TESTED FOR PROPER DRAINAGE PRIOR TO TREE PLANTING. PROVIDE APPROPRIATE DRAINAGE SYSTEM AS REQUIRED IF THE TREE PIT DOES NOT DRAIN SUFFICIENTLY.
- THE LANDSCAPE CONTRACTOR SHALL GUARANTEE ALL LANDSCAPE PLANT MATERIALS AND IRRIGATION INSTALLATION FOR A PERIOD OF ONE YEAR BEGINNING AFTER THE COMPLETION OF LANDSCAPE INSTALLATION DATE APPROVED BY THE TOWNSHIP/CITY OR LANDSCAPE ARCHITECT. THE CONTRACTOR SHALL REPLACE DURING AND AT THE END OF THE GUARANTEE PERIOD, ANY DEAD OR UNACCEPTABLE PLANTS, AS DETERMINED BY THE TOWNSHIP/CITY OR LANDSCAPE ARCHITECT, WITHOUT COST TO THE OWNER.
- PRIOR TO THE RELEASE OF THE PERFORMANCE BOND, THE CITY OF ROCHESTER HILLS MUST INSPECT ALL LANDSCAPE PLANTINGS.

city notes:

Prior approval is required to plant any tree or shrub on the public right-of-way. All trees and shrubs must be planted at least 10' from the edge of the public road. (Trees must be planted at least 15' away from curb or road edge where the speed limit is more than 35 mph.) Shade trees and shrubs must be planted at least 5' from the edge of the public walkway. Evergreen and ornamental trees must be planted at least 10' from the edge of the public walkway. No trees or shrubs may be planted within the triangular area formed at the intersection of any street right-of-way lines at a distance along each line of 25' from their point of intersection. No trees or shrubs may be planted in the triangular area formed at the intersection of any driveway with a public walkway at a distance along each line of 15' from their point of intersection. All trees and shrubs must be planted at least 10' from any fire hydrant. Shade and evergreen trees must be at least 15' away from the nearest overhead wire. Trees must be planted a minimum of 5' from an underground utility, unless the city's Landscape Architect requires a greater distance.

Prior to the release of the performance bond, the City of Rochester Hills Forestry Division needs to inspect all trees, existing or planted, to identify any that pose a hazard to the safe use of the public right-of-way. Forestry may require the developer to remove, and possibly replace, any such trees.

plant material list

key	quant.	botanical name	common name	size	unit cost	total cost
LARGE AND SMALL DECIDUOUS TREES						
ARA-4	4	ACER RUBRUM 'ARMSTRONG'	ARMSTRONG RED MAPLE (MULTI-STEM)	3" BB	1400	11600
DECIDUOUS SHRUBS						
VMK-6	6	VIBURNUM XB. 'MOHAUK'	MOHAUK VIBURNUM	3 1/2" BB	150	1300
JT-17	17	JUNIFERUS S. 'TAMARISCIFOLIA'	TAM JUNIFER	24" BB	150	1050
TN-11	11	THUJA OCCIDENTALIS 'NIGRA'	AMERICAN DARK GREEN ARBORVITAE	6" BB	115	1265
VMK-6	6	HYDRANGEA M. 'ANNABELLE'	ANNABELLE HYDRANGEA	5" CONT.	140	1240
MSS-1	1	MISCANTHUS S. 'GRACILLIMUS'	JAPANESE SILVER MAIDEN GRASS	5" CONT.	130	130
PAH-7	7	FENISTERTIA 'HAMELIN'	DWARF FOUNTAIN GRASS	5" CONT.	120	1140
					Total	13,985

landscape requirement

right-of-way landscape	REQUIRED	PROVIDED
TOTAL LIN. FT. OF R.O.W. FRONTAGE AUBURN ROAD	49 1/2	
ONE (1) DECIDUOUS OR EVERGREEN TREE PER 35 LIN. FT.	5	0 (NOTE #2)
ONE (1) ORNAMENTAL TREE PER 60 LIN. FT.	2	0 (NOTE #2)
TOTAL LIN. FT. OF R.O.W. FRONTAGE HESSELL STREET	140 1/2	
ONE (1) DECIDUOUS OR EVERGREEN TREE PER 35 LIN. FT.	4	4
ONE (1) ORNAMENTAL TREE PER 60 LIN. FT.	2	0 (NOTE #2)
parking lot perimeter	REQUIRED	PROVIDED
TOTAL LIN. FT. PARKING FRONTAGE HESSELL STREET	45 1/2	
ONE (1) DECIDUOUS OR EVERGREEN TREE PER 25 LIN. FT.	2	0 (NOTE #2)
ONE (1) ORNAMENTAL TREE PER 35 LIN. FT.	1	0 (NOTE #2)
CONTINUOUS SHRUB HEDGE	10	11

landscape buffer (type-d)

	REQUIRED	PROVIDED
TOTAL LIN. FT. OF NORTH PROPERTY BOUNDARY	49 1/2	
TWO AND HALF (2.5) DECIDUOUS TREES PER 100 LIN. FT.	2	GREENMALL (NOTE #1)
FIVE (5) EVERGREEN TREES PER 100 LIN. FT.	5	GREENMALL (NOTE #1)
ONE & ONE HALF (1.5) ORNAMENTAL TREE PER 100 LIN. FT.	15	GREENMALL (NOTE #1)
EIGHT (8) DECIDUOUS OR EVERGREEN SHRUBS PER 100 LIN. FT.	7	GREENMALL (NOTE #1)

note:

- GREEN MALL CONSISTING OF 12-EXISTING ARBORVITAE PLUS 11-NEW ARBORVITAE PER STAFF RECOMMENDATION
- DEFICIENT TREES DUE TO SITE CONSTRUCTION (2-PARKING LOT TREES, 1-ORNAMENTAL PARKING LOT TREE, 3-R.O.W. TREES, AND 4-ORNAMENTAL R.O.W. TREES) TO BE PAID TOWARDS CITY TREE FUND AT RATE A OF \$200 PER TREE. 10-TREES TOTAL AT COST OF \$2,000

cost estimate summary

TOTAL ESTIMATED PLANT MATERIALS COST	13,985.00
TOTAL ESTIMATED IRRIGATION COST	1,200.00
TOTAL ESTIMATED SOD COST	16,000.00
TOTAL MISC. ITEM COST (MULCH, EDGING, ETC.)	150.00
TOTAL ESTIMATED LANDSCAPE COST	31,335.00

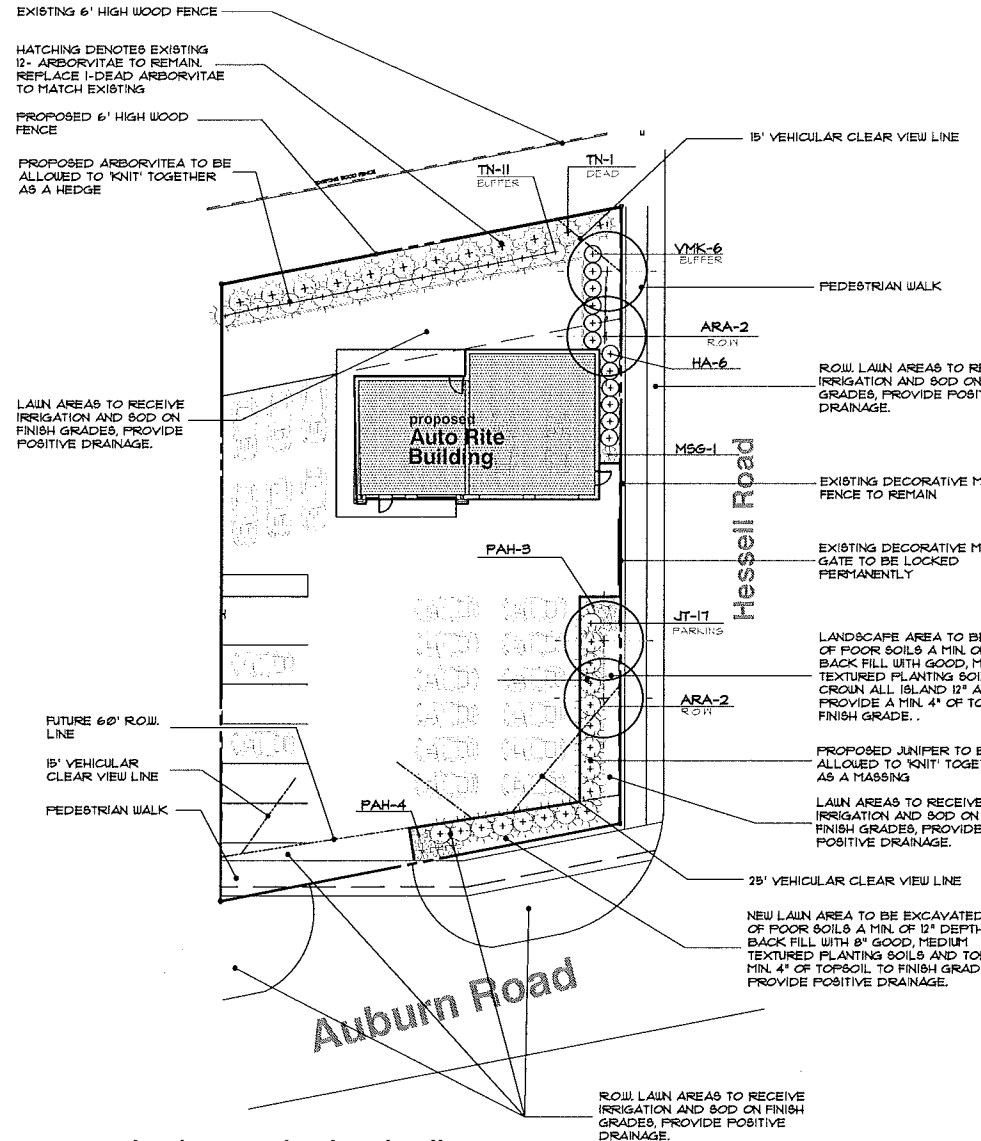

landscape planting detail
SCALE 1"=20'-0"

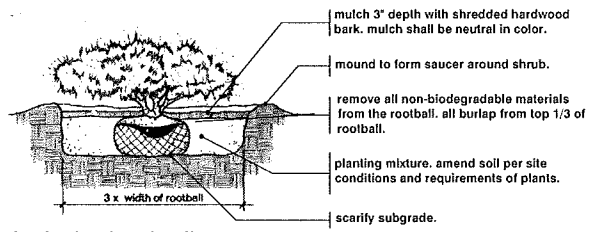

shrub planting detail
no scale

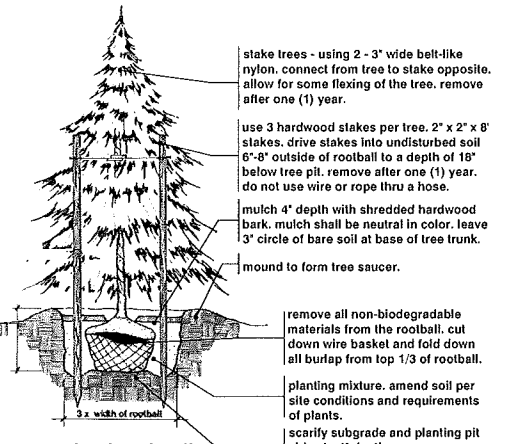

evergreen planting detail
no scale

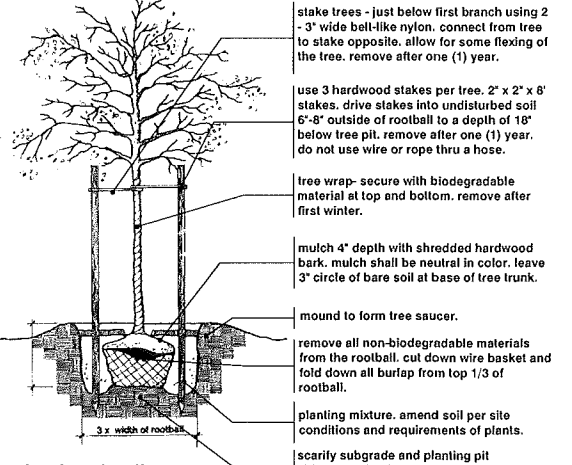

tree planting detail
no scale

FP A
FELINO A. PASCUAL
and ASSOCIATES
Community Land Planner and
registered Landscape Architect
24333 Orchard Lake Rd, Suite G
Farmington Hills, MI 48336
ph. (248) 557-5588
fax. (248) 557-5416

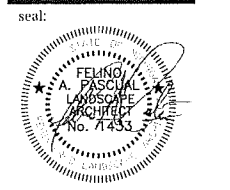

client:
AUTO RITE, LLC
1923 E. AUBURN ROAD
ROCHESTER HILLS, MICHIGAN
48307

project:
AUTO RITE SALES

project location:
Rochester Hill,
Michigan
Auburn Road

sheet title:

Job no./Issue/revision date:

LS15.049.05 SPA	5-20-2015
	6-01-2015
LS15.049.07 SPA	8-10-2015
	9-10-2015
LS15.049.11 SPA	11-10-2015
LS15.049.12 SPA	12-21-2015

drawn by:
JP
checked by:
FP
date:
5-15-2015
notice:
Copyright © 2015
This document and the subject matter contained therein is proprietary and is not to be used or reproduced without the written permission of Felino Pascual and Associates.
Do Not scale drawings. Use figured dimensions only.



The location and elevations of existing underground utilities as shown on this drawing are only approximate, no guarantee is offered except as implied, as to the completeness or accuracy. Contractor shall be exclusively responsible for determining the exact location and elevation prior to the start of construction.

LS15.049.05
sheet no:

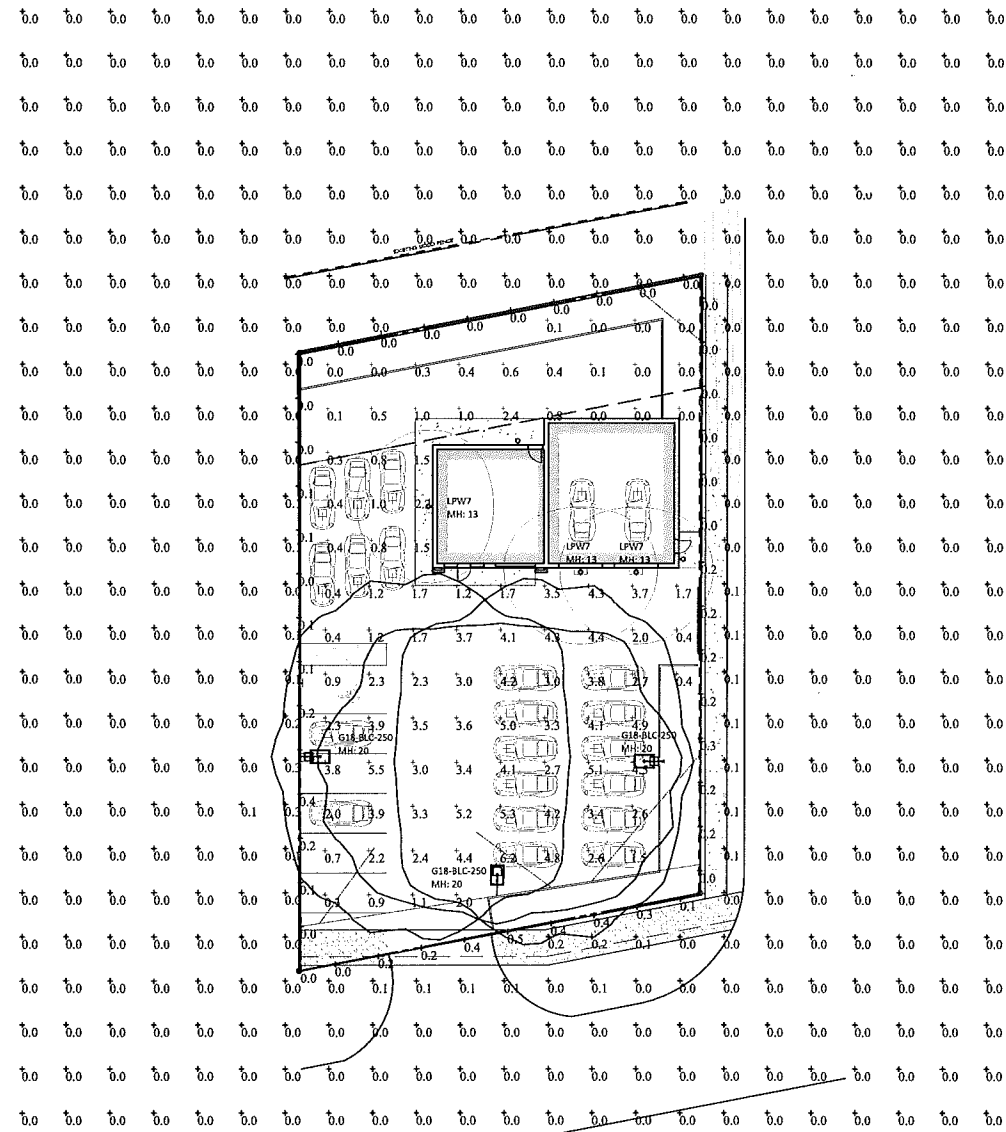

Luminaire Schedule									
Project: Auto Rite LLC - Rochester Hills, MI									
Symbol	Qty	Label	Arrangement	Total Lamp Lumens	Lum. Lumens	LLF	Description	Lum. Watts	BUG Rating
	3	G18-BLC-250	SINGLE	22000	7597	0.750	G18-BLC-250PSMH	250	B1-U0-G2
	3	LPW7	SINGLE	N.A.	1154	0.850	LPW7	14	B1-U0-G0

ALL POLE FIXTURES ARE SHOWN AT 20 FEET ABOVE FINISHED GRADE
 ALL WALL FIXTURES ARE SHOWN AT 13 FEET ABOVE FINISHED GRADE

Calculation Summary							
Project: Auto Rite LLC - Rochester Hills, MI							
Label	CalcType	Units	Avg	Max	Min	Avg/Min	Max/Min
FC Beyond Prop Line at Grade	Illuminance	Fc	0.01	0.3	0.0	N.A.	N.A.
Grass Perimeter FC at Grade	Illuminance	Fc	0.52	2.4	0.0	N.A.	N.A.
Paved Lot Area FC	Illuminance	Fc	3.11	6.2	0.3	10.37	20.67
Property Line FC at Grade	Illuminance	Fc	0.13	0.5	0.0	N.A.	N.A.
Walkway Entrance FC	Illuminance	Fc	0.42	0.6	0.2	2.10	3.00

ALL VALUES SHOWN ARE HORIZONTAL MAINTAINED FOOTCANDLES AT GRADE
 FIXTURE DISTRIBUTION TEMPLATES ARE SHOWN AT 0.25MFC FOR REFERENCE USE ONLY
 VALUES DO NOT INCLUDE CONTRIBUTION FROM ADJACENT STREET OR PROPERTY LIGHTING



AUTO RITE LLC - ROCHESTER HILLS, MI - PHOTOMETRIC PLAN - PHILIPS GULLWING SERIES -250W PSMH

391-11656-R1

COPYRIGHT © 2015
 THIS DOCUMENT AND SUBJECT MATTER CONTAINED THEREIN IS THE PROPERTY OF CHESTER STEMPEN ASSOCIATES. IT IS TO BE USED ONLY FOR THE PROJECT AND NOT BE REPRODUCED OR TRANSMITTED IN ANY FORM OR BY ANY MEANS WITHOUT THE WRITTEN PERMISSION OF CHESTER STEMPEN ASSOC.

PROJECT
AUTO RITE LLC
 1927 E. ALBURN RD.
 ROCHESTER HILLS, MI 48307

SUBJECT
PHOTOMETRIC PLAN

ARCHITECTS
CHESTER STEMPEN ASSOCIATES • AIA
 29895 CREEKFIELD ROAD SOUTHFIELD, MICHIGAN 48076
 (248) 557-2145 FAX: (248) 569-2856



ISSUED:
 PLANNING: 11/10/2015
 REVISION: 12/21/2015

DRAWN: VB
 CHECKED: C.F.S.
 APPROVED: C.F.S.
 DES:
 CONSTR:

DO NOT SCALE
 PRINTS - USE
 DIMENSIONS ONLY

JOB NO.
24001

SHEET
E.1